

**GENERAL NOTES:**

1. ASSA/40mm & 60mm BERTHA ROLL-UP SHOWN ON THIS PRODUCT EVALUATION DOCUMENT (P.E.D.) HAS BEEN VERIFIED FOR CODE COMPLIANCE IN ACCORDANCE WITH THE 2010 EDITION OF THE FLORIDA BUILDING CODE. ASSA/40mm & 60mm BERTHA ROLL-UP SHALL NOT BE INSTALLED AT HIGH VELOCITY HURRICANE ZONES (MIAMI-DADE/BROWARD COUNTIES).

DESIGN WIND LOADS SHALL BE DETERMINED AS PER SECTION 1609 OF THE ABOVE MENTIONED CODE, FOR A WIND SPEED AS REQUIRED BY THE JURISDICTION WHERE THESE SHUTTERS WILL BE INSTALLED AND FOR A DIRECTIONALITY FACTOR  $K_d=0.85$ . USING ASCE 7-10 FOR INSTALLATIONS UNDER 2010 FBC AND SHALL NOT EXCEED THE MAXIMUM (A.S.D.) DESIGN PRESSURE RATINGS INDICATED ON SHEETS 4 THRU 14.

IN ORDER TO VERIFY THE ABOVE CONDITION, ULTIMATE DESIGN WIND LOADS DETERMINED PER ASCE 7-10 SHALL BE FIRST REDUCED TO A.S.D. DESIGN WIND LOADS BY MULTIPLYING THEM BY 0.6 IN ORDER TO COMPARE THESE W/ MAX. (A.S.D.) DESIGN PRESSURE RATINGS INDICATED ON SHEETS 4 THRU 14.

IN ORDER TO VERIFY THAT COMPONENTS AND ANCHORS ON THIS P.E.D. AS TESTED WERE NOT OVER STRESSED, A 33% INCREASE IN ALLOWABLE STRESS FOR WIND LOADS WAS NOT USED IN THEIR ANALYSIS, HOWEVER, A DURATION FACTOR  $CD=1.60$  WAS USED FOR VERIFICATION OF FASTENERS IN WOOD.

ASSA/40mm & 60mm BERTHA ROLL-UP'S ADEQUACY FOR IMPACT AND FATIGUE RESISTANCE HAS BEEN VERIFIED IN ACCORDANCE WITH SECTION 1609.1.2 OF THE ABOVE MENTIONED CODE AS PER TAS-201, 202 & 203 PROTOCOLS PER FENESTRATION TESTING LAB REPORTS #2749, 2751 & 2760 AND ATL REPORT # 0619.01-02.

2. ALL ALUMINUM EXTRUSIONS SHALL BE ALUMINUM ASSOCIATION 6063-T6 ALLOY & TEMPER (SEE COMPONENTS SHEET).

3. ALL SCREWS TO BE STAINLESS STEEL 304 OR 316 AISI SERIES OR CORROSION RESISTANT COATED CARBON STEEL AS PER DIN 50018 W/ 50 ksi YIELD STRENGTH AND 90 ksi TENSILE STRENGTH & SHALL COMPLY W/ FLORIDA BUILDING CODE SECTION 2411.3.3.4. ALL TEK SCREWS SHALL BE AS MANUFACTURED BY ITW BUILDEX, INC.

4. BOLTS TO BE A.S.T.M. A-307 GALVANIZED STEEL OR AISI 304 SERIES STAINLESS STEEL, WITH 35 ksi MINIMUM YIELD STRENGTH.

5. STORM BARS AT FLOOR AND CEILING MOUNTING INSTALLATIONS MAY BE REMOVABLE AT NON HURRICANE CONDITIONS. HOWEVER, EACH STORM BAR SHALL BEAR A PERMANENT LABEL IN A VISIBLE PLACE WITH A WARNING NOTE INSTRUCTING THE TENANT OR OWNER THAT STORM BARS MUST BE INSTALLED WITH CORRESPONDING HARDWARE DURING PERIODS OF HURRICANE WARNING AND THAT ROLL UP SHUTTERS WILL NOT OFFER HURRICANE PROTECTION UNLESS ALL STORM BAR ARE INSTALLED AS DIRECTED.

6. REMOVABLE STORM BARS SHALL BE STORED IN A CONSPICUOUS PLACE WITH EASY AND IMMEDIATE ACCESS SO THAT THEY CAN BE REACHED AND INSTALLED ANY TIME (HURRICANE CONDITIONS OR NOT) SLATS ARE ROLLED DOWN. THE EFFECT OF THE SLATS ROLLED DOWN WITHOUT STORM BARS IS; THOSE SLATS WILL SLIP OUT OF TRACK DUE TO THE DEFLECTION CAUSED BY WIND FORCES.

7. ANCHORS TO WALL FOR SIDE RAILS & BOX CONNECTION SHALL BE AS FOLLOWS (UNLESS OTHERWISE NOTED):

- (A) TO EXISTING POURED CONCRETE: (Min.  $f'c=3192$  psi)
  - 1/4"Ø TAPCON ANCHORS, AS MANUFACTURED BY ITW BUILDEX.

**NOTES:**

A.1) MINIMUM EMBEDMENT OF TAPCON ANCHORS INTO POURED CONCRETE IS 1 3/4". NO EMBEDMENT INTO STUCCO SHALL BE CONSIDERED AS PART OF THE REQUIRED EMBEDMENT.

A.2) MINIMUM EDGE DISTANCE OF TAPCON ANCHORS INTO CONCRETE BLOCK SHALL BE 2 1/2".

A.3) IN CASE THAT PRECAST STONE, PRECAST CONCRETE PANELS, OR PAVERS BE FOUND ON THE EXISTING WALL OR FLOOR, ANCHORS SHALL BE LONG ENOUGH TO REACH THE MAIN STRUCTURE BEHIND SUCH PANELS. ANCHORAGE SHALL BE AS INDICATED ON NOTES A.1 ABOVE.

- (B) TO EXISTING CONCRETE ASTM C-90 BLOCK WALL:
  - 1/4"Ø TAPCON ANCHORS AS MANUFACTURED BY ITW BUILDEX.

**NOTES:**

B.1) MINIMUM EMBEDMENT OF TAPCON ANCHORS INTO CONCRETE BLOCK UNIT SHALL BE 1 1/4". NO EMBEDMENT INTO STUCCO SHALL BE CONSIDERED AS PART OF THE REQUIRED EMBEDMENT.

B.2) MINIMUM EDGE DISTANCE OF TAPCON ANCHORS INTO CONCRETE BLOCK SHALL BE 2 1/2".

B.3) IN CASE THAT PRECAST STONE OR PRECAST CONCRETE PANELS BE FOUND ON THE EXISTING WALL, ANCHORS SHALL BE LONG ENOUGH TO REACH THE MAIN STRUCTURE BEHIND SUCH PANELS.

- (C) TO EXISTING WOOD FRAME BUILDING: SOUTHERN PINE #2 W/  $G = 0.55$  MIN.

**NOTES:**

-1/4"Ø LAG SCREWS PER N.D.S. 2005.

C.1) MINIMUM THREADED PENETRATION OF LAG SCREWS, INTO THE WOOD FRAME UNIT SHALL BE 1 1/2". NO THREADED PENETRATION INTO STUCCO SHALL BE CONSIDERED AS PART OF THE REQUIRED THREADED PENETRATION.

C.2) MINIMUM EDGE DISTANCE OF LAG SCREWS INTO WOOD SHALL BE 2".

C.3) IN CASE THAT PRECAST STONE, PRECAST CONCRETE OR BRICK PANELS, VENEER OR PAVERS BE FOUND ON THE EXISTING WALL, ANCHORS SHALL BE LONG ENOUGH TO REACH THE MAIN SUBSTRATE BEHIND SUCH PANELS. MINIMUM THREADED PENETRATION SHALL BE AS INDICATED ON NOTE C.1 ABOVE.

8. ANCHORS SHALL BE INSTALLED FOLLOWING ALL OF THE RECOMMENDATIONS AND SPECIFICATIONS OF THE ANCHOR'S MANUFACTURER.

9. ANCHORS REQUIRED FOR STORM BARS, HEADER & MULLIONS CONNECTIONS SHALL BE AS SPECIFIED ON APPLICABLE SECTIONS SHOWN ON SHEETS 5, 5A, 5B, 6 & 7 OF 14 RESPECTIVELY. TAPCON ANCHORS AS MANUFACTURED BY ITW BUILDEX, POWER BOLT & CALK-IN ANCHORS TO BE AS MANUFACTURER BY POWERS FASTENERS, INC. AND KWIK BOLT TZ EXPANSION ANCHORS TO BE AS MANUFACTURED HILTI, INC. MINIMUM EDGE DISTANCE AND SPACING FOR ABOVE MENTIONED ANCHORS SHALL BE AS INDICATED BELOW OR AS SHOWN ON CORRESPONDING DETAILS FOR EACH SHUTTER COMPONENT INSTALLATION IN THIS DRAWING, WHICHEVER IS LARGER (MORE CRITICAL).

ANCHOR	SPACING	EDGE DISTANCE	MINIMUM EMBEDMENT	
			POURED CONCRETE	CONCRETE BLOCK
-1/4"Ø TAPCON	3"	3"	1 3/4" (Min. $f'c=3192$ psi)	1 1/4" (ASTM C-90)
-1/4"Ø CALK-IN	2 1/2"	3"	7/8" (Min. $f'c=3000$ psi)	-
-3/8"Ø CALK-IN	3 3/4"	4 1/2"	1 1/4" (Min. $f'c=3000$ psi)	-
-3/8"Ø POWER BOLT	3 3/4"	4 1/2"	1 3/4" (Min. $f'c=3000$ psi)	1 1/4" (ASTM C-90)
-3/8"Ø KWIK BOLT TZ	6"	4 3/8"	2" (Min. $f'c=3000$ psi)	-
-1/2"Ø KWIK BOLT TZ	9 3/4"	6"	3 1/4" (Min. $f'c=3000$ psi)	-

10. IT SHALL BE THE RESPONSIBILITY OF THE CONTRACTOR TO VERIFY THE SOUNDNESS OF THE STRUCTURE WHERE SHUTTER IS TO BE ATTACHED TO INSURE PROPER ANCHORAGE. THIS SHUTTER SHALL ONLY BE ATTACHED TO CONCRETE, BLOCK OR WOOD FRAME BUILDINGS.

11. THE INSTALLATION CONTRACTOR IS TO SEAL/CAULK ALL SHUTTER COMPONENT EDGES WHICH REMAIN IN CONTINUOUS CONTACT WITH THE BUILDING TO PREVENT WIND/RAIN INTRUSION. CAULK AND SEAL SHUTTER TRACKS ALL AROUND FULL LENGTH.

12. ROLL-UP MECHANISM NOT PART OF THIS APPROVAL, BUT SHALL BE CERTIFIED BY AN INDEPENDENT TESTING AGENCY.

13. ASSA/40mm & 60mm BERTHA ROLL-UP INSTALLATION SHALL COMPLY WITH SPECS INDICATED IN THIS DRAWING PLUS ANY BUILDING AND ZONING REGULATIONS PROVIDED BY THE JURISDICTION WHERE PERMIT IS APPLIED TO.

14. (a) THIS P.E.D. PREPARED BY THIS ENGINEER IS GENERIC AND DOES NOT PROVIDE INFORMATION FOR A SITE SPECIFIC PROJECT; I.E. WHERE THE SITE CONDITIONS DEVIATE FROM THE P.E.D.

(b) CONTRACTOR TO BE RESPONSIBLE FOR THE SELECTION, PURCHASE AND INSTALLATION INCLUDING LIFE SAFETY OF THIS PRODUCT, BASED ON THIS P.E.D. PROVIDED HE/SHE DOES NOT DEVIATE FROM THE CONDITIONS DETAILED ON THIS DOCUMENT. CONSTRUCTION SAFETY AT SITE IS THE CONTRACTOR'S RESPONSIBILITY.

(c) THIS P.E.D. WILL BE CONSIDERED INVALID IF ALTERED BY ANY MEANS.

(d) SITE SPECIFIC PROJECTS SHALL BE PREPARED BY A FLORIDA REGISTERED ENGINEER OR ARCHITECT WHICH WILL BECOME THE ENGINEER OF RECORD (E.O.R.) FOR THE PROJECT AND WHO WILL BE RESPONSIBLE FOR THE PROPER USE OF THE P.E.D. ENGINEER OF RECORD, ACTING AS A DELEGATED ENGINEER TO THE P.E.D. ENGINEER, SHALL SUBMIT TO THIS LATTER THE SITE SPECIFIC DRAWINGS FOR REVIEW.

(e) THIS P.E.D. SHALL BEAR THE DATE AND ORIGINAL SEAL AND SIGNATURE OF THE PROFESSIONAL ENGINEER OF RECORD THAT PREPARED IT.

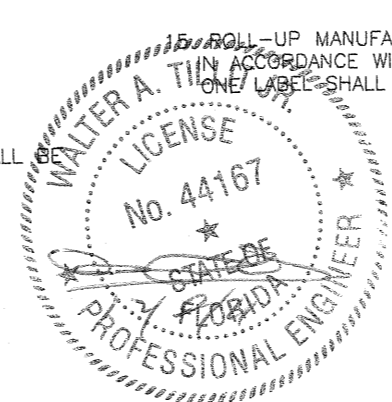

ROLL-UP MANUFACTURER'S LABEL SHALL BE LOCATED ON A READILY VISIBLE LOCATION AT ASSA/40mm & 60mm BERTHA ROLL-UP IN ACCORDANCE WITH SECTION 1715.8.3 OF FLORIDA BUILDING CODE. ONE LABEL SHALL BE PLACED FOR EVERY OPENING. LABELING TO COMPLY WITH SECTION 1715.8.2 OF THE FLORIDA BUILDING CODE.

**FLORIDA BUILDING CODE (Non High Velocity Hurricane Zone)**

<p>© 2011 TILTECO, INC. TILTECO inc. TILLIT TESTING &amp; ENGINEERING COMPANY 6355 N.W. 36th St., Ste. 305, VIRGINIA GARDENS, FL 33166 Phone : (305)871-1530 . Fax : (305)871-1531 e-mail: tilteco@aol.com EB-0006719 WALTER A. TILLIT Jr. P.E. FLORIDA Lic. # 44167</p>		ASSA/40mm & 60mm BERTHA ROLL-UP AMERICAN SHUTTER SYSTEMS ASSOC., INC. 4268 WESTROADS DRIVE WEST PALM BEACH, FL. 33407 Phone : (877) 999-2772 . Fax : (561) 209-8380	DRAWN BY: L.G./A.G.  12/07/11 DATE  11-209 DRAWING No  SHEET 1 OF 14		
REV. NO	DESCRIPTION	DATE	REV. No	DESCRIPTION	DATE
1	OLD 08-157	12/07/11	3		
2			4		

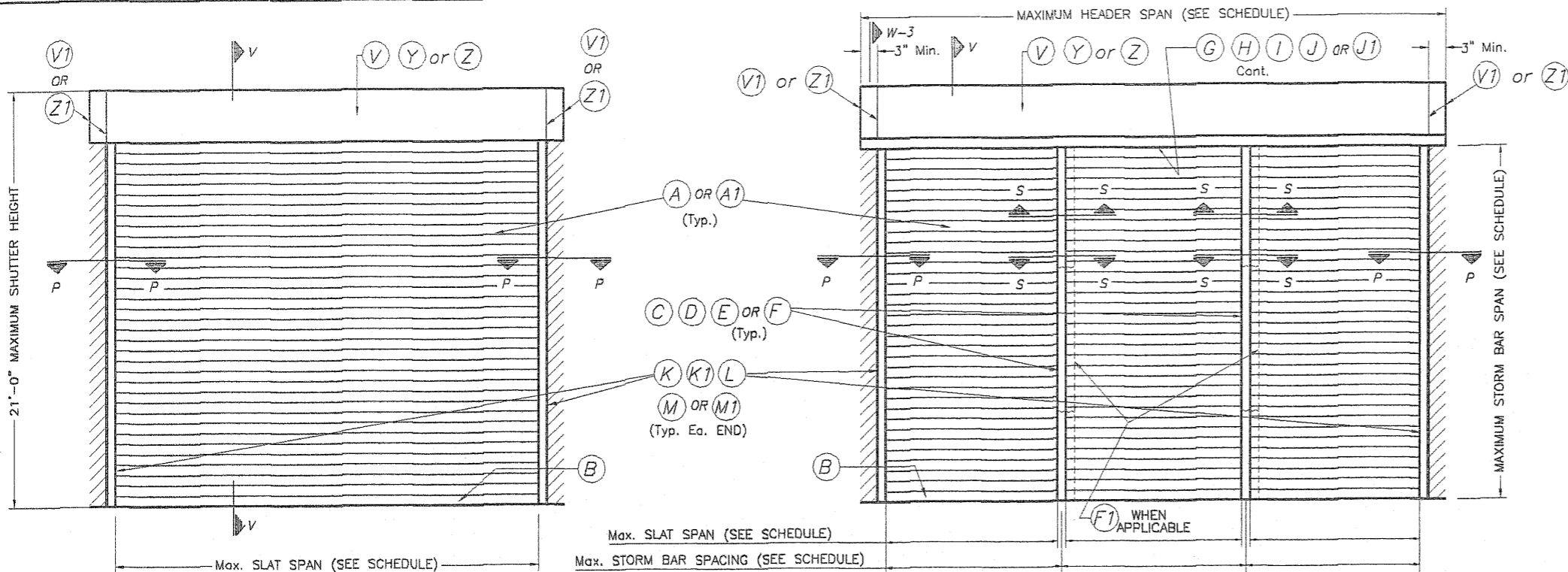

**TYPICAL SINGLE UNIT ELEVATION (NO STORM BARS REQUIRED)**

NOTE: SEE SHEET 2 & 3 OF 14 FOR COMPONENTS NOMENCLATURE.

**TYPICAL MULTIPLE UNIT ELEVATION (STORM BARS REQUIRED)**

NOTE: SEE SHEET 2 & 3 OF 14 FOR COMPONENTS NOMENCLATURE.

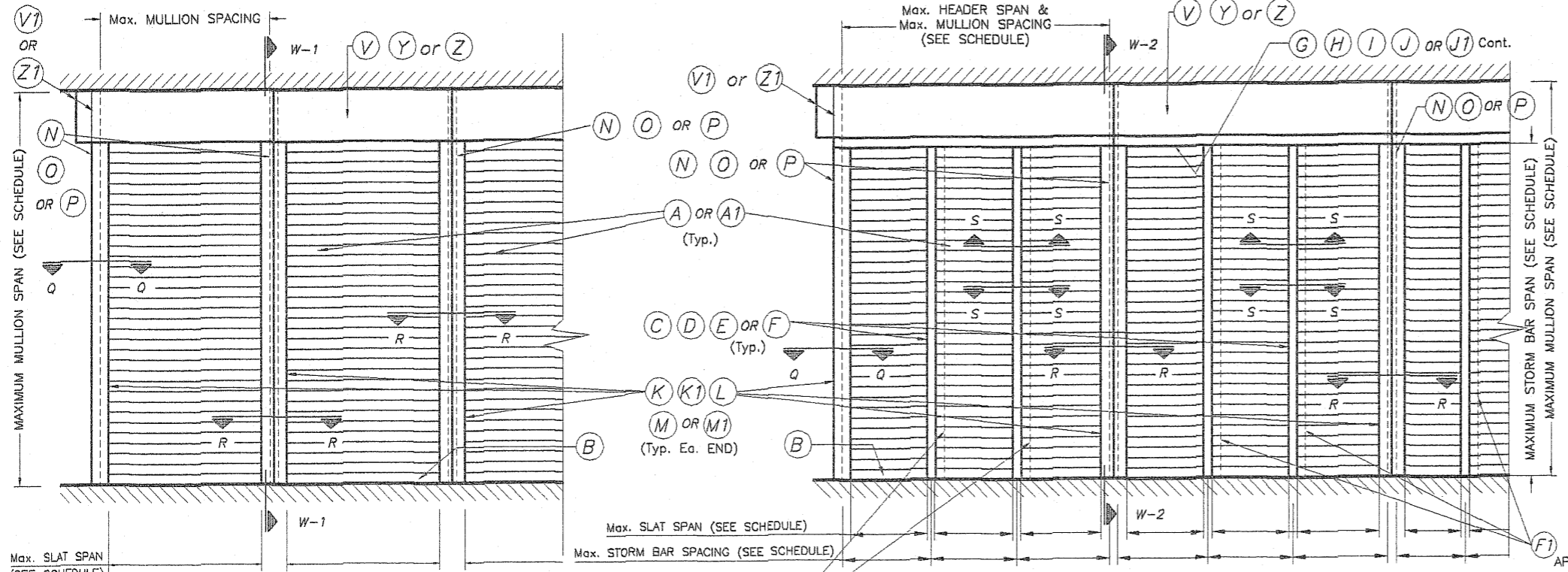

**TYPICAL CONSECUTIVE SINGLE UNIT ELEVATION (NO STORM BARS REQUIRED)**

NOTE: SEE SHEET 2 & 3 OF 14 FOR COMPONENTS NOMENCLATURE.

**TYPICAL CONSECUTIVE MULTIPLE UNIT ELEVATION (STORM BARS REQUIRED)**

NOTE: SEE SHEET 2 & 3 OF 14 FOR COMPONENTS NOMENCLATURE.

NOTE:  
SEE SECTIONS ON  
SHEETS 4 THRU 7.

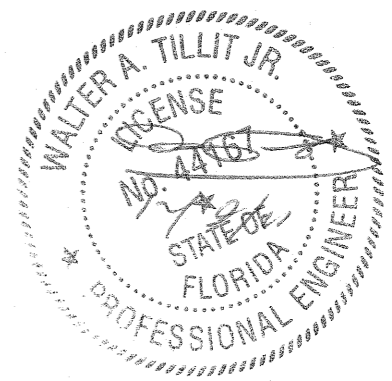

FLORIDA BUILDING CODE (Non High Velocity Hurricane Zone)

<p>© 2011 TILTECO, INC.</p> <p><b>TILTECO inc.</b></p> <p>TILLIT TESTING &amp; ENGINEERING COMPANY          6355 N.W. 36th St., Ste. 305, VIRGINIA GARDENS, FL 33166          Phone : (305)871-1530 . Fax : (305)871-1531          e-mail: tiltco@aol.com          EB-0006719          WALTER A. TILLIT Jr. P.E.          FLORIDA Lic. # 44167</p>		<p>ASSA/40mm &amp; 60mm BERTHA ROLL-UP</p> <p>AMERICAN SHUTTER SYSTEMS ASSOC., INC.</p> <p>4268 WESTROADS DRIVE          WEST PALM BEACH, FL 33407          Phone : (877) 999-2772 . Fax : (561) 209-8380</p>	<p>DRAWN BY: L.G./A.B.F.P.</p> <p>12/07/11 DATE</p> <p>11-209 DRAWING No</p>																	
<table border="1"> <thead> <tr> <th>REV. NO</th> <th>DESCRIPTION</th> <th>DATE</th> <th>REV. No</th> <th>DESCRIPTION</th> <th>DATE</th> </tr> </thead> <tbody> <tr> <td>1</td> <td>OLD 08-157</td> <td>12/07/11</td> <td>3</td> <td></td> <td></td> </tr> <tr> <td>2</td> <td>MAX. SHUTTER HEIGHT</td> <td>03/18/09</td> <td>4</td> <td></td> <td></td> </tr> </tbody> </table>	REV. NO	DESCRIPTION	DATE	REV. No	DESCRIPTION	DATE	1	OLD 08-157	12/07/11	3			2	MAX. SHUTTER HEIGHT	03/18/09	4			<p>SHEET 1A OF 14</p>	
REV. NO	DESCRIPTION	DATE	REV. No	DESCRIPTION	DATE															
1	OLD 08-157	12/07/11	3																	
2	MAX. SHUTTER HEIGHT	03/18/09	4																	

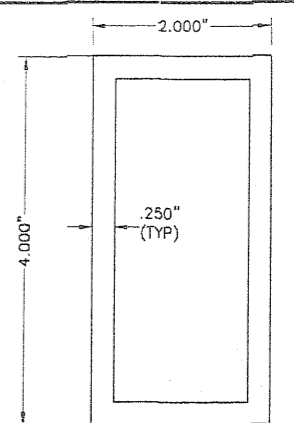
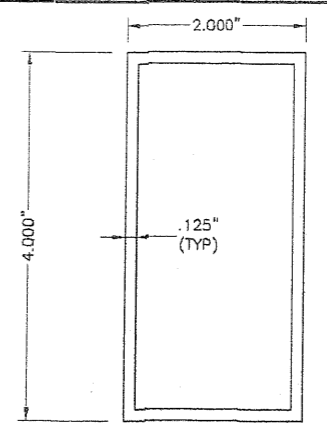
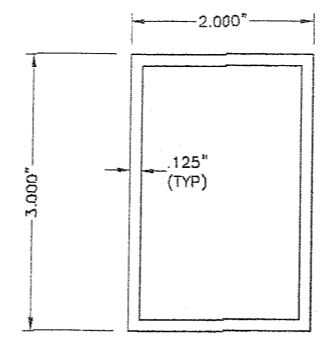
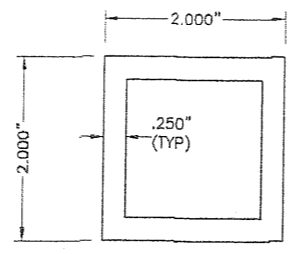
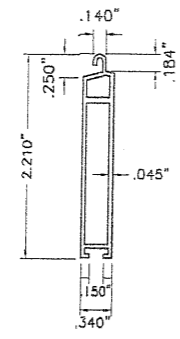
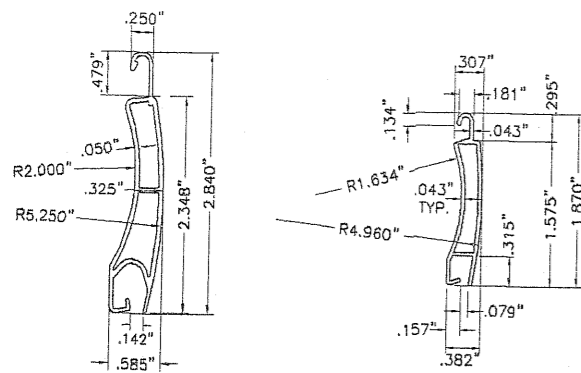

**(A) TYPE 1 SLAT:**

60 mm EXTRUDED ALUMINUM SLAT  
6063-T6 ALUMINUM ALLOY  
SCALE: 1/2" = 1"

**(A1) TYPE 2 SLAT:**

40 mm EXTRUDED ALUMINUM SLAT  
6063-T6 ALUMINUM ALLOY  
SCALE: 1/2" = 1"

**(B) BOTTOM SLAT:**

EXTRUDED ALUMINUM BOTTOM SLAT  
6063-T6 ALUMINUM ALLOY  
SCALE: 1/2" = 1"

**(C) TYPE 1 STORM BAR:**

2" EXTRUDED STORM BAR  
6063-T6 ALUMINUM ALLOY  
SCALE: 1/2" = 1"

**(D) TYPE 2 STORM BAR:**

3" EXTRUDED STORM BAR  
6063-T6 ALUMINUM ALLOY  
SCALE: 1/2" = 1"

**(E) TYPE 3 STORM BAR:**

4" EXTRUDED STORM BAR  
6063-T6 ALUMINUM ALLOY  
SCALE: 1/2" = 1"

**(F) TYPE 4 STORM BAR:**

4" HEAVY EXTRUDED STORM BAR  
6063-T6 ALUMINUM ALLOY  
SCALE: 1/2" = 1"

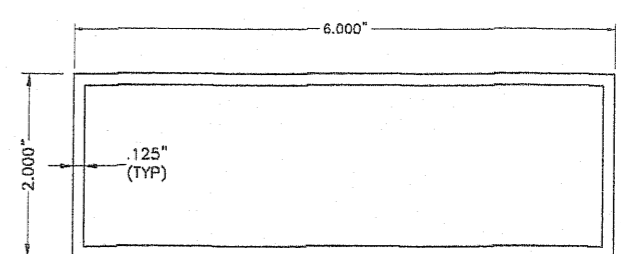
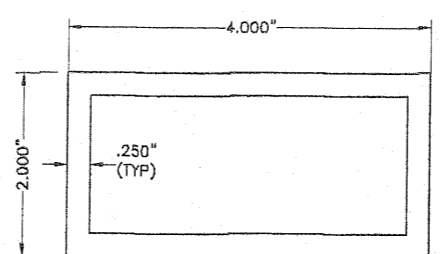
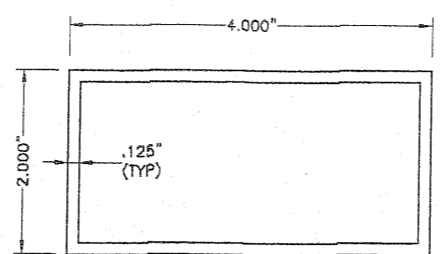
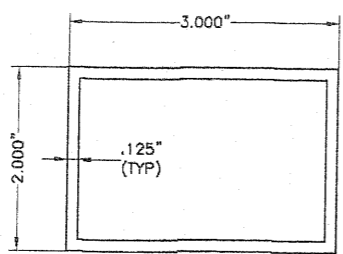
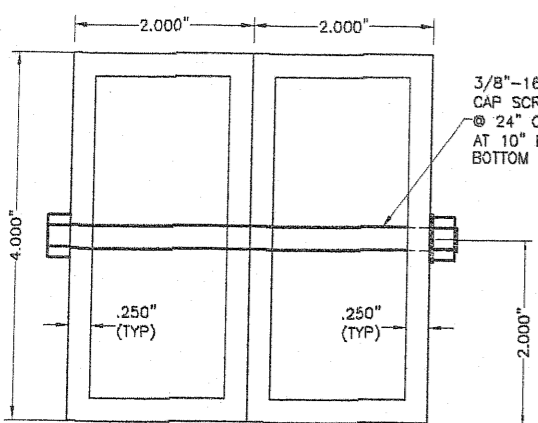

**(G) HEADER TYPE 1:**

6063-T6 ALUMINUM ALLOY  
SCALE: 1/2" = 1"

**(H) HEADER TYPE 2:**

6063-T6 ALUMINUM ALLOY  
SCALE: 1/2" = 1"

**(I) HEADER TYPE 3:**

6063-T6 ALUMINUM ALLOY  
SCALE: 1/2" = 1"

**(J) HEADER TYPE 4:**

6063-T6 ALUMINUM ALLOY  
SCALE: 1/2" = 1"

**(F1) TYPE 5 STORM BAR:**

4" HEAVY EXTRUDED STORM BAR  
6063-T6 ALUMINUM ALLOY  
SCALE: 1/2" = 1"

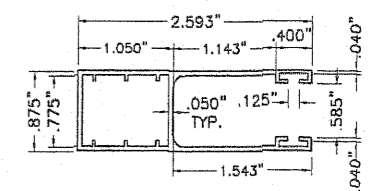
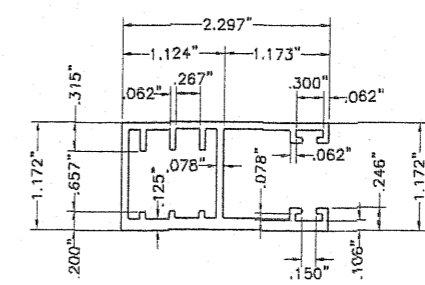
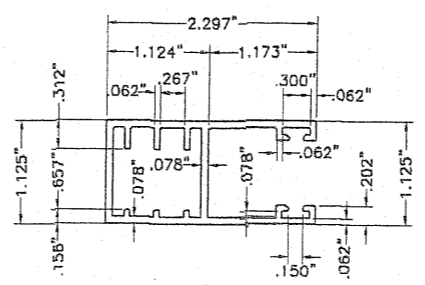
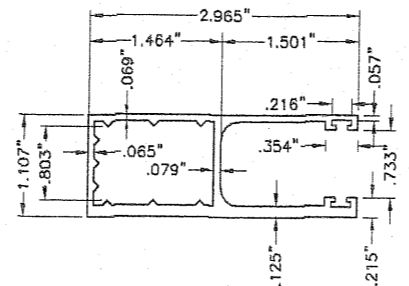
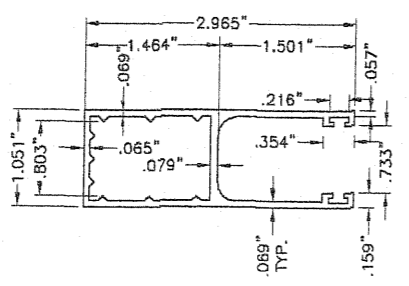
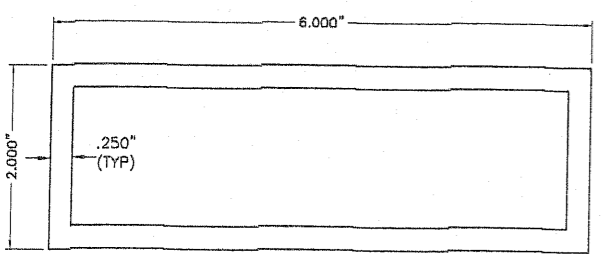

**(K) TYPE 1 SIDE RAIL: FOR (A)**

6063-T6 Alum. ALLOY  
SCALE: 1/2" = 1"

**(K1) TYPE 2 SIDE RAIL: FOR (A)**

6063-T6 Alum. ALLOY  
SCALE: 1/2" = 1"

**(L) TYPE 3 SIDE RAIL: FOR (A)**

6063-T6 Alum. ALLOY  
SCALE: 1/2" = 1"

**(M) TYPE 4 SIDE RAIL: FOR (A)**

6063-T6 Alum. ALLOY  
SCALE: 1/2" = 1"

**(M1) TYPE 5 SIDE RAIL: FOR (A1)**

6063-T6 Alum. ALLOY  
SCALE: 1/2" = 1"

**(J1) HEADER TYPE 5:**

6063-T6 ALUMINUM ALLOY  
SCALE: 1/2" = 1"

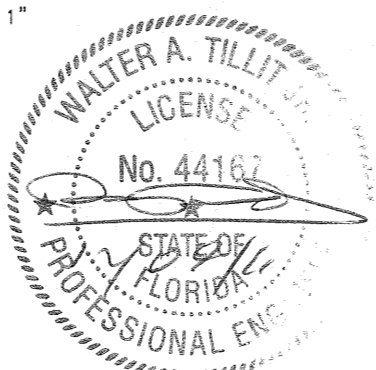

FLORIDA BUILDING CODE (Non High Velocity Hurricane Zone)

© 2011 TILTECO, INC.		ASSA/40mm & 60mm BERTHA ROLL-UP		DRAWN BY: L.G./A.G.	
		AMERICAN SHUTTER SYSTEMS ASSOC., INC.		12/07/11 DATE	
		4268 WESTROADS DRIVE WEST PALM BEACH, FL. 33407 Phone : (877) 999-2772 . Fax : (561) 209-8380		11-209 DRAWING No	
REV. NO	DESCRIPTION	DATE	REV. No	DESCRIPTION	DATE
1	OLD 06-157	12/07/11	3		
2			4		
					SHEET 2 OF 14

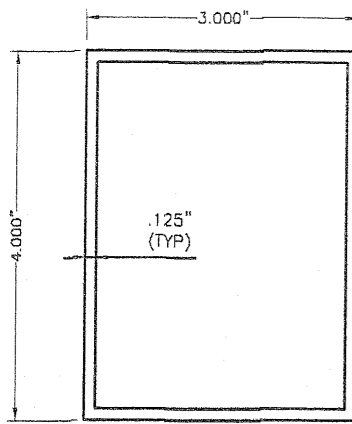

**(N) TYPE 1 MULLION:**  
4" EXTRUDED MULLION  
6063-T6 ALUMINUM ALLOY  
SCALE: 1/2" = 1"

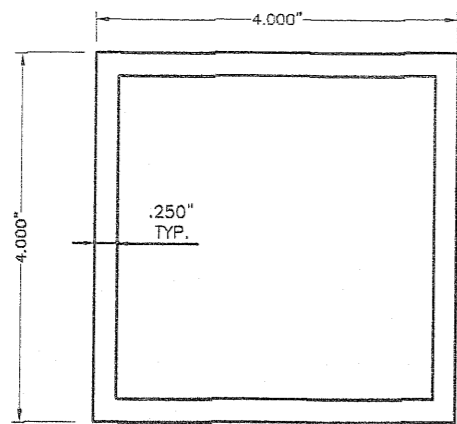

**(O) TYPE 2 MULLION:**  
4" EXTRUDED MULLION  
6063-T6 ALUMINUM ALLOY  
SCALE: 1/2" = 1"

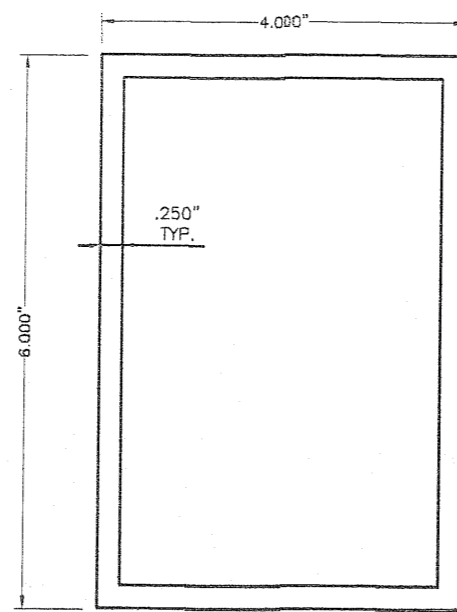

**(P) TYPE 3 MULLION:**  
6" EXTRUDED MULLION  
6063-T6 ALUMINUM ALLOY  
SCALE: 1/2" = 1"

2 CONCRETE ANCHORS SPACED  
2" O. C. VERTICALLY W/ 3/4"  
EDGE DISTANCE TOP & BOTTOM.

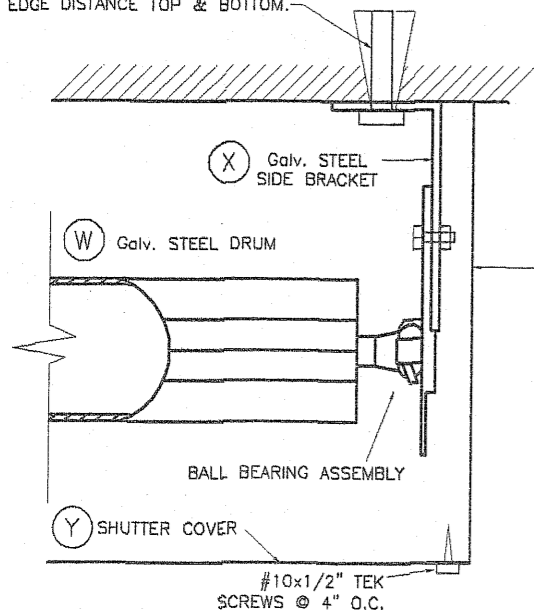

**BRACKET DETAIL 1**

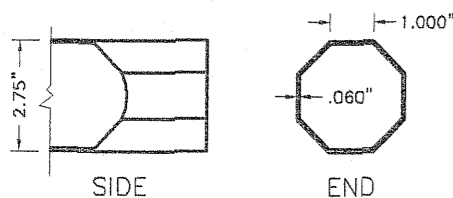

**(W) DRUM \***

SCALE: 1/4" = 1"  
1010 ELITE ROLLED STEEL F. E.  
P. O. 1 Z 200 DESIGNATION  
F<sub>tu</sub> = 410 NW/MM2. % OF STRETCH  
MINIMAL ON TEST. BAR OF 80 MM: 24 %  
G-90 GALVANIZED COATING Thk.: .060"

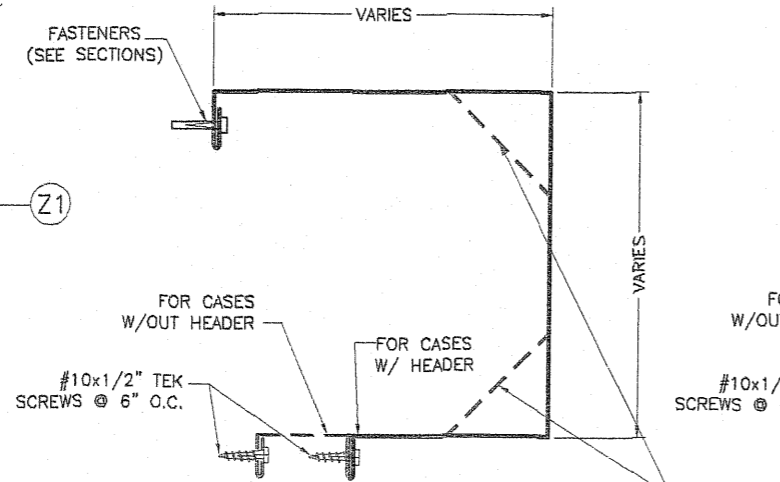

**(Y) WALL HOUSING \***

SCALE: 3/16" = 1"  
3105-H14 ALUMINUM ALLOY  
THICKNESS: .032"

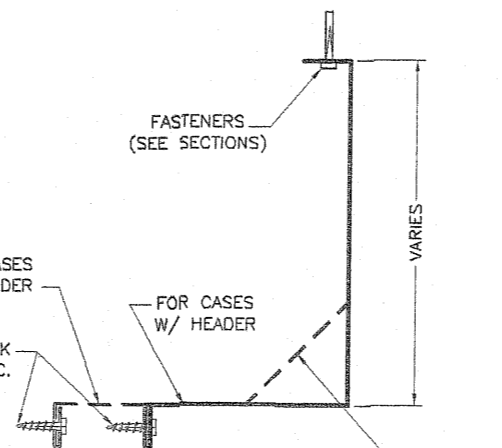

**(Z) WALL HOUSING \***

SCALE: 3/16" = 1"  
3105-H14 ALUMINUM ALLOY  
THICKNESS: .032"

**(Z1) SHUTTER SIDE COVER \***

SCALE: 3/16" = 1"  
3105-H14 ALUMINUM ALLOY  
THICKNESS: .032"

\* SEE NOTE 12 ON SHEET 1 OF 14

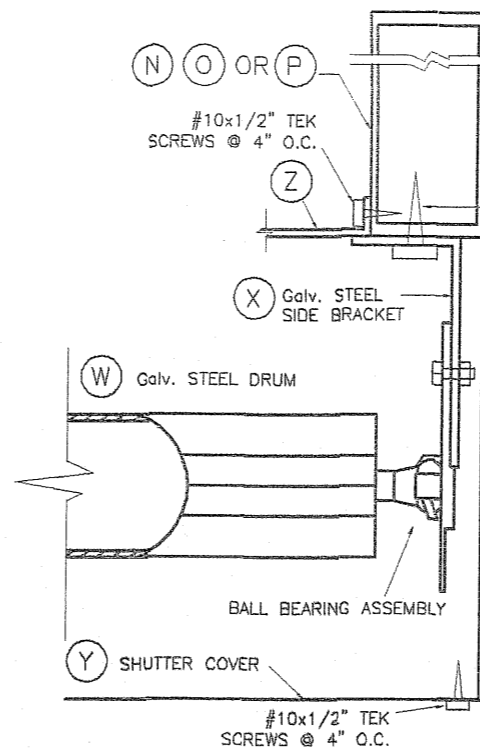
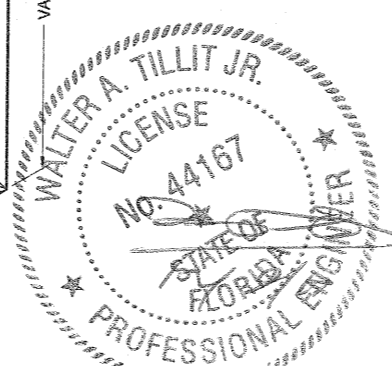

**BRACKET DETAIL 1A**

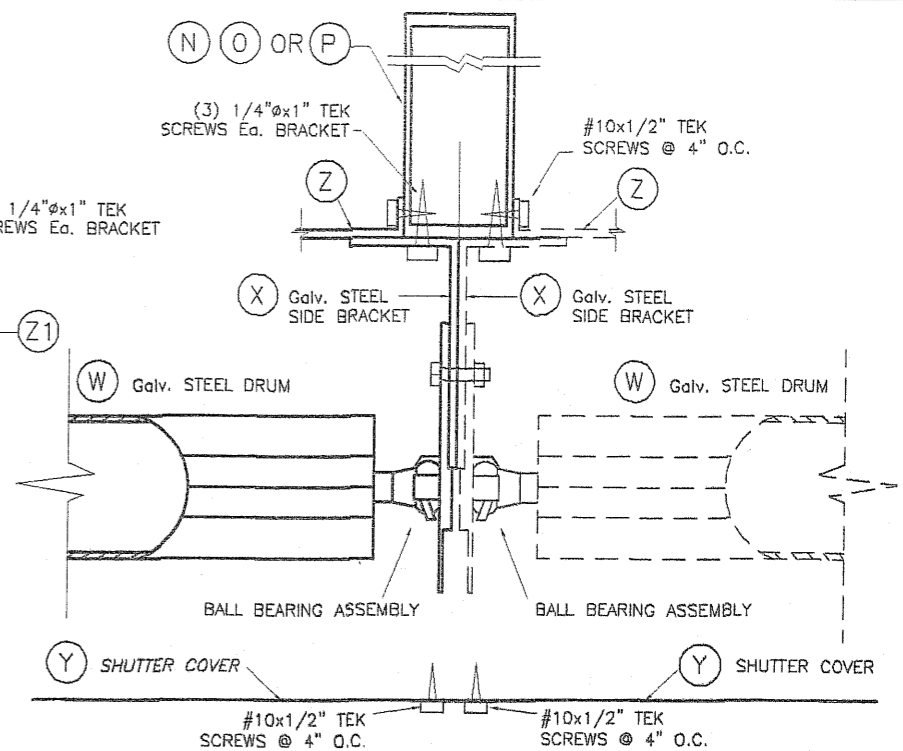

**BRACKET DETAIL 2**

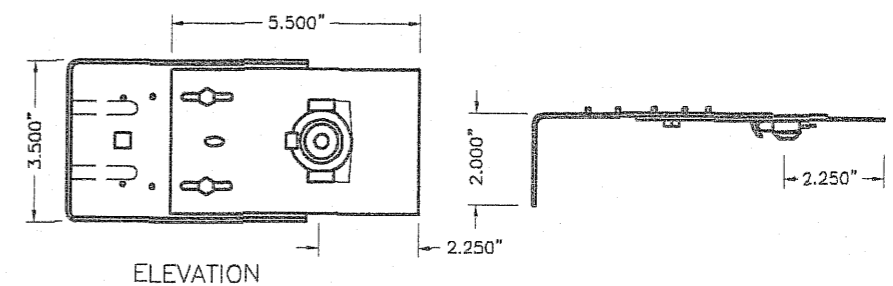

ELEVATION

**(X) SIDE BRACKET \***

SCALE: 1/4" = 1"  
1010 ELITE ROLLED STEEL F. E.  
P. O. 1 Z 200 DESIGNATION  
F<sub>tu</sub> = 410 NW/MM2. % OF STRETCH  
MINIMAL ON TEST. BAR OF 80 MM: 24 %  
G-90 GALVANIZED COATING Thk.: .060"

SEE SHEET 3A FOR ALTERNATE ROLL-UP SHUTTER LIFTING MECHANISMS

FLORIDA BUILDING CODE (Non High Velocity Hurricane Zone)

© 2011 TILTECO, INC.		ASSA/40mm & 60mm BERTHA ROLL-UP		DRAWN BY: L.G./A.G.	
		AMERICAN SHUTTER SYSTEMS ASSOC., INC.		12/07/11 DATE	
		4268 WESTROADS DRIVE WEST PALM BEACH, FL. 33407 Phone : (877) 999-2772 . Fax : (561) 209-8380		11-209 DRAWING No	
REV. NO	DESCRIPTION	DATE	REV. NO	DESCRIPTION	DATE
1	OLD 08-157	12/07/11	3		
2			4		
				SHEET 3 OF 14	



TYPE 10 : 12"  
 TYPE 9 : 10"  
 TYPE 8 : 9"  
 TYPE 7 : 8"  
 TYPE 6 : 7"  
 TYPE 5 : 6.5"  
 TYPE 4 : 6"  
 TYPE 3 : N/A  
 TYPE 2 : N/A  
 TYPE 1 : N/A

TYPE 10 : N/A  
 TYPE 9 : 10"  
 TYPE 8 : 9"  
 TYPE 7 : 8"  
 TYPE 6 : 7"  
 TYPE 5 : 6.5"  
 TYPE 4 : 6"  
 TYPE 3 : 5.5"  
 TYPE 2 : 5"  
 TYPE 1 : 4"

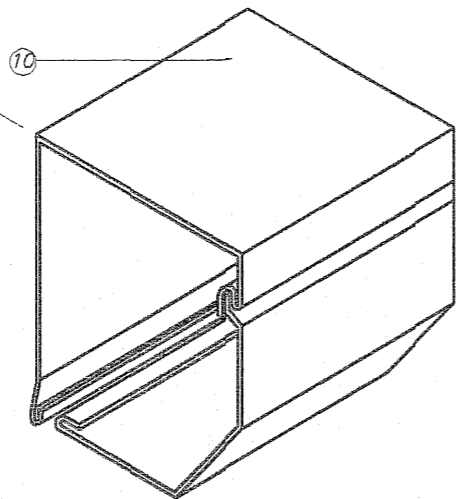

**RV 45 & RV 45/S  
 HOUSINGS**

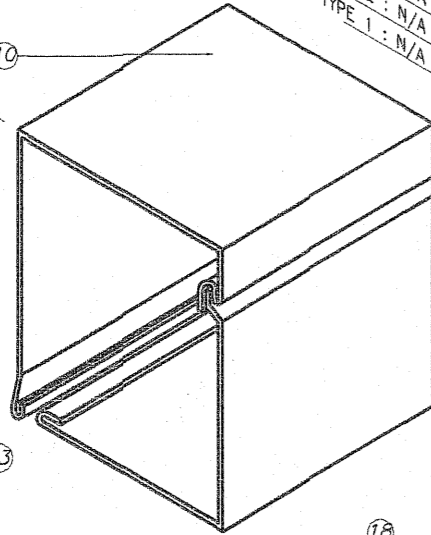

**RV 90 HOUSING**

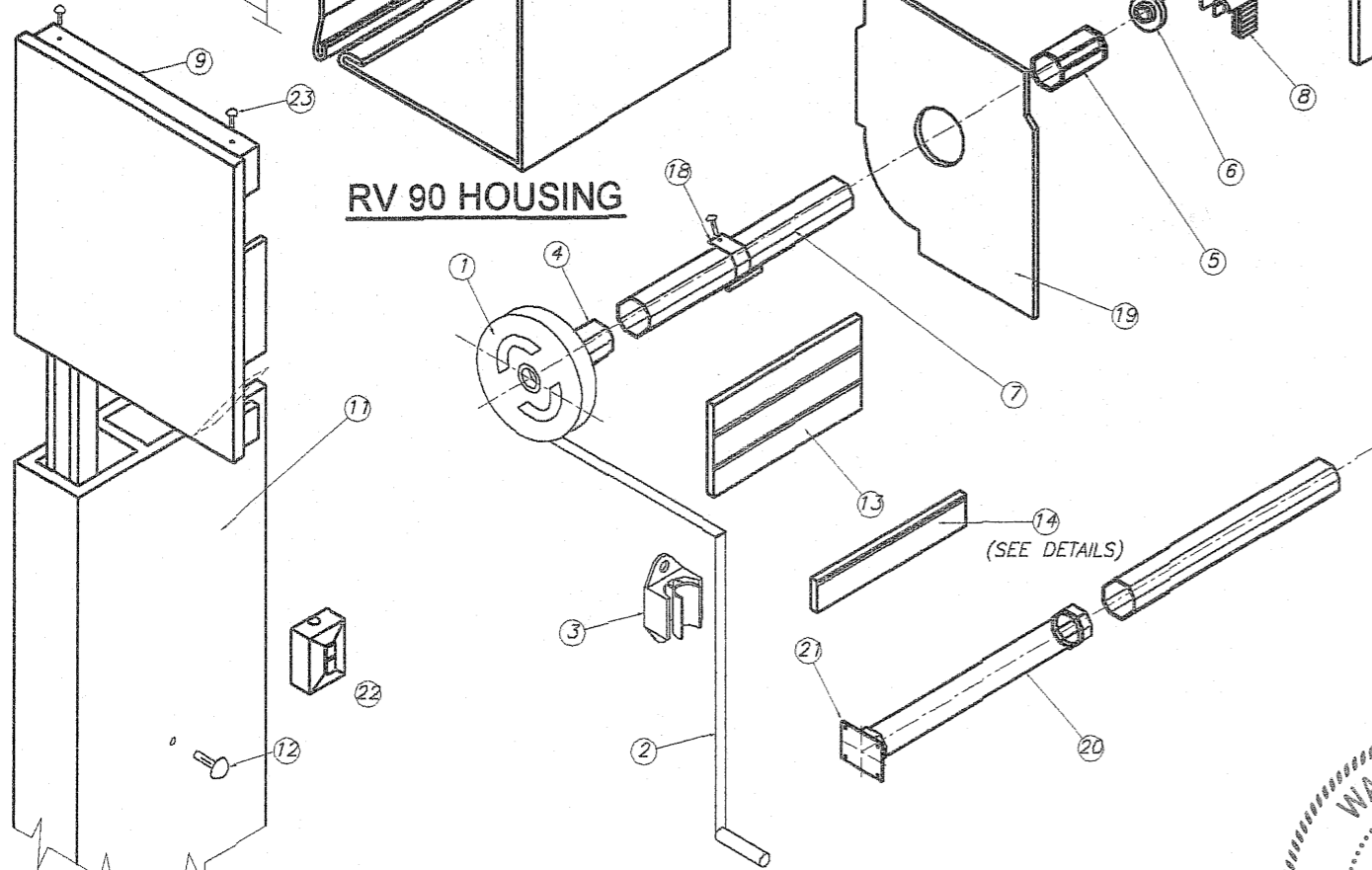

**(V) BOX COMPONENTS AND ASSEMBLY DETAIL  
 END CAP SYSTEM**

SEE SHEET 3 FOR ALTERNATE ROLL-UP SHUTTER LIFTING MECHANISMS  
 (SEE NOTE 12 ON SHEET 1 OF 14)

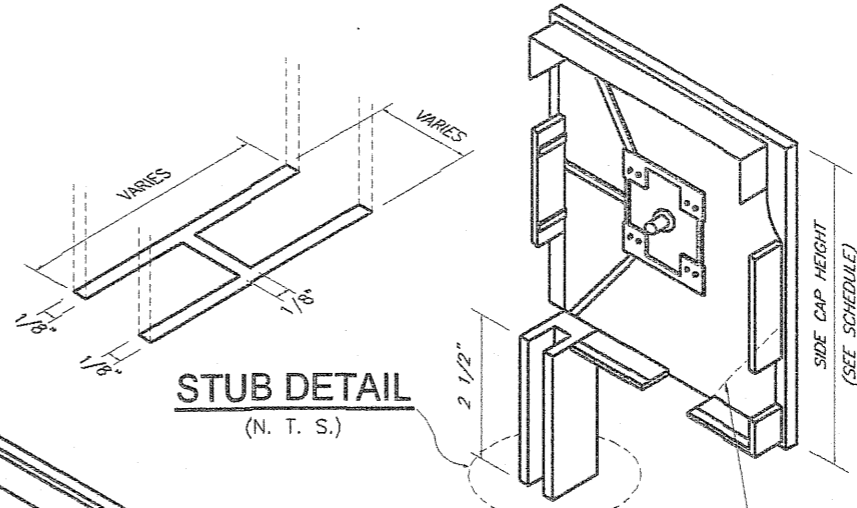

**STUB DETAIL  
 (N. T. S.)**

**(V1) SIDE CAPS:**

45° CHAMFER  
 AS APPLICABLE

**COMPONENTS FOR GEAR OPERATED SYSTEM**

- ① - GEAR
- ② - UNIVERSAL & CRANK
- ③ - CRANK HOLDER(OPTIONAL)
- ④ - GEAR INSERT(GEAR TO AXLE CONNECTOR)
- ⑤ - IDLER INSERT
- ⑥ - BALL BEARING
- ⑦ - OCTAGONAL AXLE \*
- ⑧ - ENTRY GUIDES
- ⑨ - SIDE/END CAP \*
- ⑩ - HOUSING(FRONT & BOTTOM), 0.040" THICK
- ⑪ - SIDE RAIL
- ⑫ - PLUG-BUTTONS
- ⑬ - ALUMINUM SLATS
- ⑭ - BASE SLAT
- ⑮ - PLASTIC STOPS(OPTIONAL)
- ⑯ - SIDE LOCKS(OPTIONAL)
- ⑰ - STAPLES(OPTIONAL)
- ⑱ - SPRINGLOCK HANGER
- ⑲ - SAFETY PLATES

\* SHALL BE CAPABLE TO SUSTAIN SLAT'S  
 WEIGHT AND ASSURE LIFTING MECHANISM  
 (SEE NOTE 12/1)

**ADDITIONAL COMPONENTS FOR  
 MOTORIZED OPERATED SYSTEM**

- ⑳ - TUBULAR MOTOR
- ㉑ - MOTOR BRACKET
- ㉒ - SWITCH

**FASTENERS**

- ㉓ - 3/16" ALUMINUM POP RIVETS(6 REQ'D EA.  
 SIDE CAP) : 2 @ TOP, 2 @ REAR, 2 @ BOTTOM

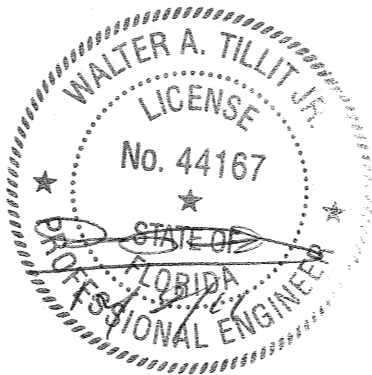

**FLORIDA BUILDING CODE (Non High Velocity Hurricane Zone)**

© 2011 TILTECO, INC.		ASSA/40mm & 60mm BERTHA ROLL-UP		DRAWN BY: L.G./A.G.	
 TILIT TESTING & ENGINEERING COMPANY 6355 N.W. 36th St., Ste. 305, VIRGINIA GARDENS, FL 33166 Phone : (305)871-1530 . Fax : (305)871-1531 e-mail: tilteco@aol.com EB-0006719 WALTER A. TILLIT JR. P.E. FLORIDA Lic. # 44167		AMERICAN SHUTTER SYSTEMS ASSOC., INC.		12/07/11 DATE	
		4268 WESTROADS DRIVE WEST PALM BEACH, FL. 33407 Phone : (877) 999-2772 . Fax : (561) 209-8380		11-209 DRAWING No	
REV. NO	DESCRIPTION	DATE	REV. NO	DESCRIPTION	DATE
1	OLD 08-157	12/07/11	3		
2			4		
					SHEET 3A OF 14

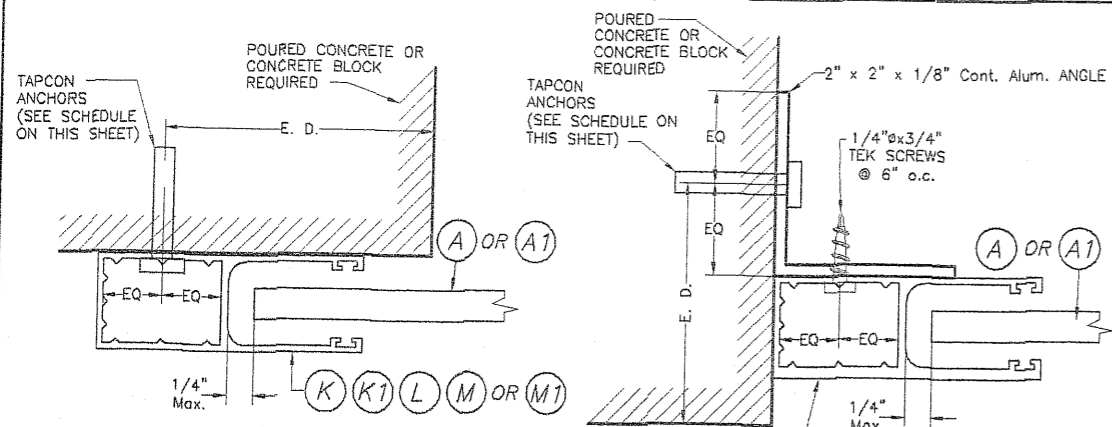

**SECTION P - P (1) : WALL MOUNT**

SCALE: 1/2" = 1"

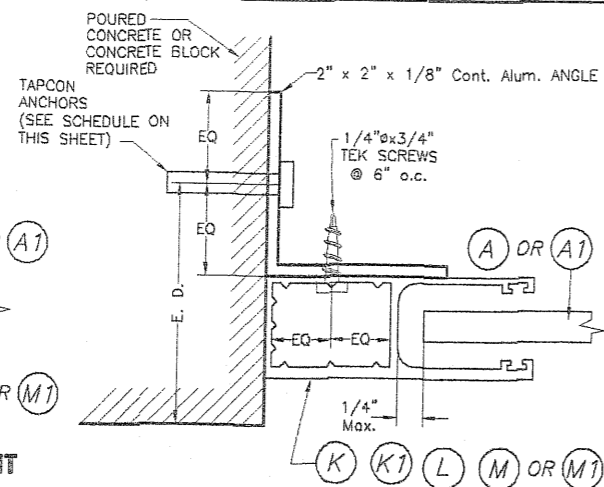

**SECTION P - P (2) : SIDE WALL MOUNT**

SCALE: 1/2" = 1"

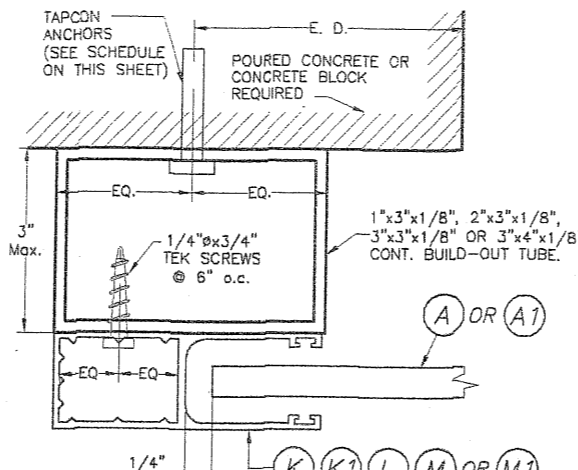

**SECTION P - P (3) : BUILD-OUT MOUNT**

SCALE: 1/2" = 1"

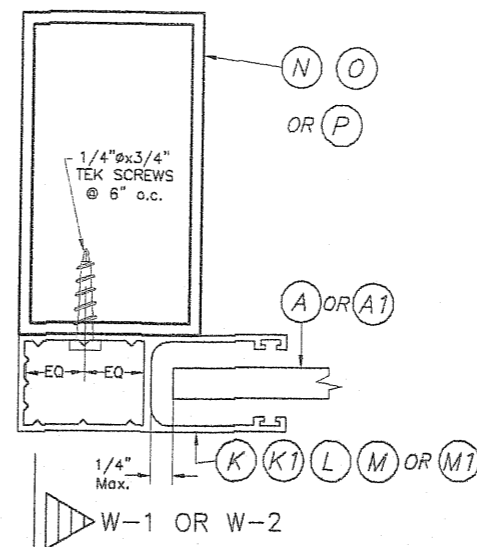

**SECTION Q - Q : MULLION MOUNT (FACE MOUNT)**

SCALE: 1/2" = 1"

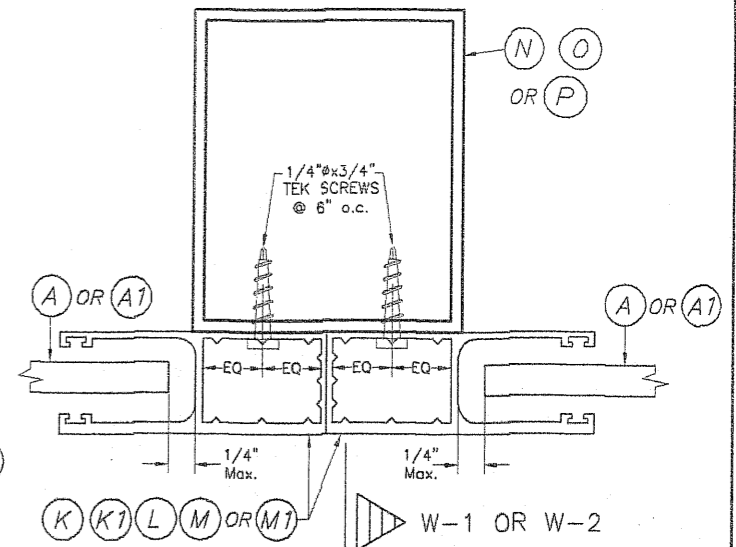

**SECTION R - R : MULLION MOUNT (FACE MOUNT)**

SCALE: 1/2" = 1"

**SIDE RAIL ANCHOR SCHEDULE MAXIMUM A.S.D. DESIGN PRESSURE RATING (p. s. f.) AND CORRESPONDING MAXIMUM ANCHOR SPACING(in) \* FOR SIDE RAILS (K), (K1), (L) & (M) CONNECTION TO POURED CONCRETE OR CONCRETE BLOCK WALL (USE MAXIMUM VALUES BETWEEN POSITIVE AND NEGATIVE LOAD)**

MAXIMUM A.S.D. DESIGN PRESSURE RATING (p.s.f.)	SIDE RAIL (K)			SIDE RAIL (K1)			SIDE RAIL (L)			SIDE RAIL (M)		
	WALL MOUNT	INSIDE MOUNT	BUILD-OUT MOUNT	WALL MOUNT	INSIDE MOUNT	BUILD-OUT MOUNT	WALL MOUNT	INSIDE MOUNT	BUILD-OUT MOUNT	WALL MOUNT	INSIDE MOUNT	BUILD-OUT MOUNT
80 OR LESS	6"	3 1/2"	6"	6"	3 1/2"	6"	6"	4"	6"	6"	4"	6"
>80 TO 150	3"	-	5"	3"	-	5"	4"	3"	6"	4"	3"	6"
	6"	5 1/2"	6"	6"	5 1/2"	6"	6"	6"	6"	6"	6"	6"
>150 TO 195	3"	-	4 1/2"	3"	-	4 1/2"	3 1/2"	-	5 1/2"	3 1/2"	-	5 1/2"
	6"	5"	6"	6"	5"	6"	6"	6"	6"	6"	6"	6"

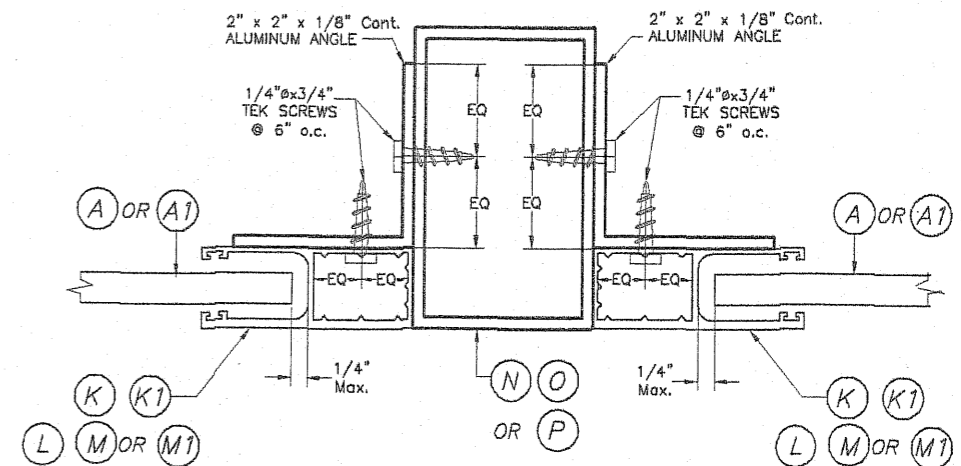

**SECTION R - R : MULLION MOUNT (INSIDE MOUNT)**

SCALE: 1/2" = 1"

**SIDE RAIL ANCHOR SCHEDULE MAXIMUM A.S.D. DESIGN PRESSURE RATING (p. s. f.) AND CORRESPONDING MAXIMUM ANCHOR SPACING(in) \* FOR SIDE RAIL (M1) CONNECTION TO POURED CONCRETE OR CONCRETE BLOCK WALL (USE MAXIMUM VALUES BETWEEN POSITIVE AND NEGATIVE LOAD)**

MAXIMUM A.S.D. DESIGN PRESSURE RATING (p.s.f.)	SIDE RAIL (M1)		
	WALL MOUNT	INSIDE MOUNT	BUILD-OUT MOUNT
80.0 OR LESS	6"	6"	6"
>80.0 TO 100.0	6"	6"	6"
	6"	6"	6"

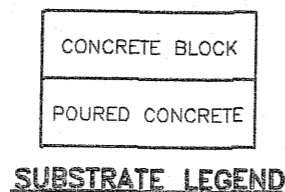

**\* MAXIMUM ANCHOR SPACING (in.) AT SIDE RAILS VERSUS EDGE DISTANCE = E. D.**

MAXIMUM SIDE RAILS ANCHOR SPACINGS SHOWN ON THIS SHEET ARE VALID FOR 3" EDGE DISTANCE.

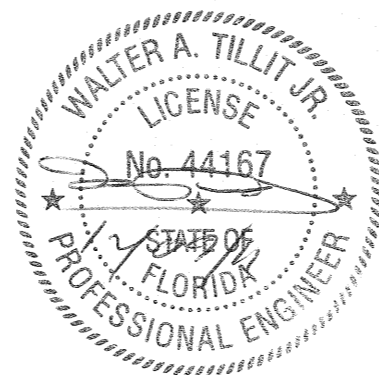

FLORIDA BUILDING CODE (Non High Velocity Hurricane Zone)

© 2011 TILTECO, INC.		ASSA/40mm & 60mm BERTHA ROLL-UP		DRAWN BY: L.G./A.G.	
 TILLIT TESTING & ENGINEERING COMPANY 6355 N.W. 36th St., Ste. 305, VIRGINIA GARDENS, FL 33166 Phone : (305)871-1530 . Fax : (305)871-1531 e-mail: tiltco@aol.com EB-0006719 WALTER A. TILLIT Jr. P.E. FLORIDA Lic. # 44167		AMERICAN SHUTTER SYSTEMS ASSOC., INC.		12/07/11 DATE	
		4268 WESTROADS DRIVE WEST PALM BEACH, FL. 33407 Phone : (877) 999-2772 . Fax : (561) 209-8380		11-209	
REV. NO	DESCRIPTION	DATE	REV. No	DESCRIPTION	DATE
1	OLD 08-157	12/07/11	3		
2			4		
					DRAWING No
					SHEET 4 OF 14

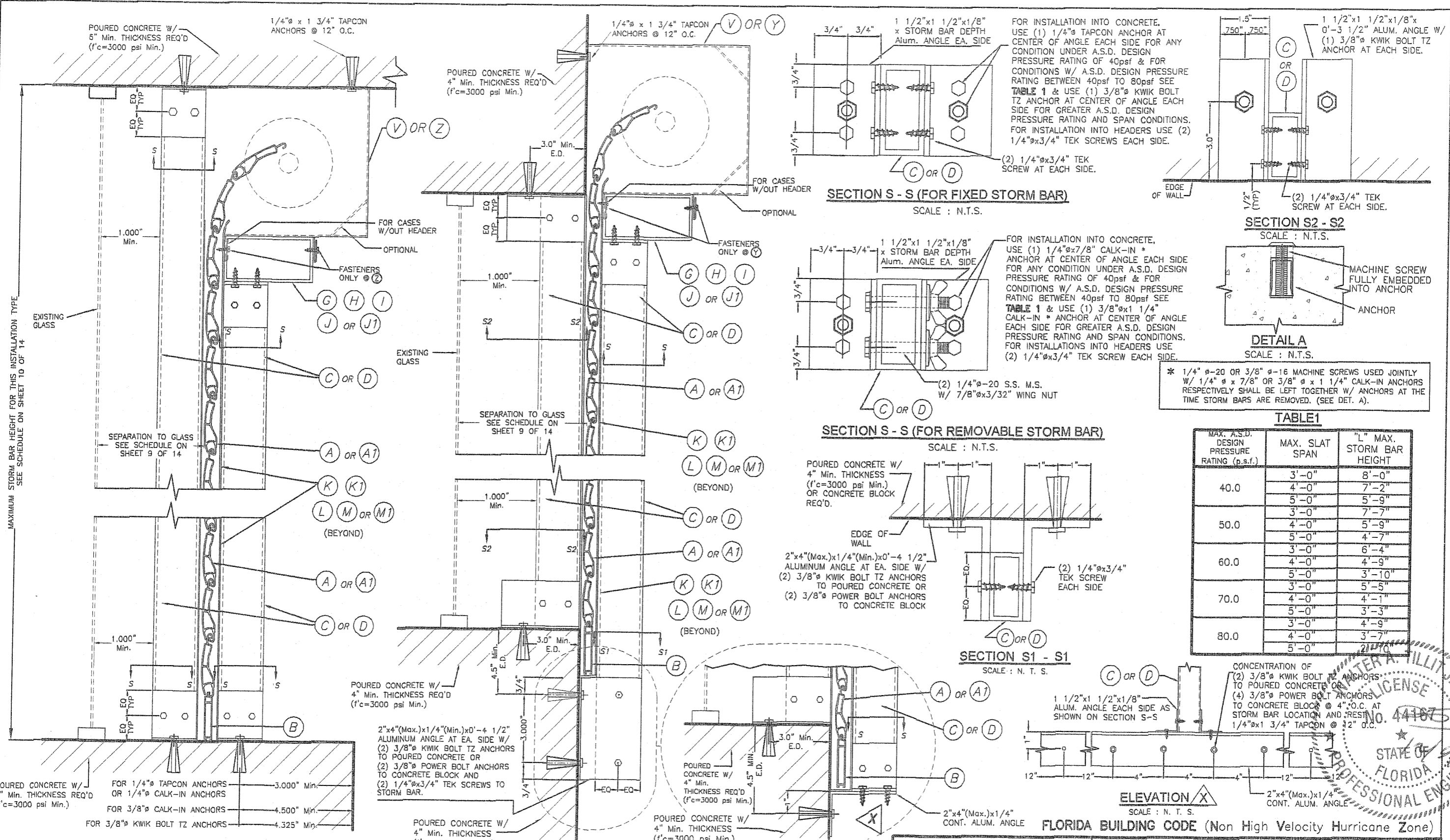

FOR INSTALLATION INTO CONCRETE, USE (1) 1/4" TAPCON ANCHOR AT CENTER OF ANGLE EACH SIDE FOR ANY CONDITION UNDER A.S.D. DESIGN PRESSURE RATING OF 40psf & FOR CONDITIONS W/ A.S.D. DESIGN PRESSURE RATING BETWEEN 40psf TO 80psf SEE TABLE 1 & USE (1) 3/8" KWIK BOLT TZ ANCHOR AT CENTER OF ANGLE EACH SIDE FOR GREATER A.S.D. DESIGN PRESSURE RATING AND SPAN CONDITIONS. FOR INSTALLATION INTO HEADERS USE (2) 1/4"x3/4" TEK SCREWS EACH SIDE.

FOR INSTALLATION INTO CONCRETE, USE (1) 1/4"x7/8" CALK-IN \* ANCHOR AT CENTER OF ANGLE EACH SIDE FOR ANY CONDITION UNDER A.S.D. DESIGN PRESSURE RATING OF 40psf & FOR CONDITIONS W/ A.S.D. DESIGN PRESSURE RATING BETWEEN 40psf TO 80psf SEE TABLE 1 & USE (1) 3/8"x1 1/4" CALK-IN \* ANCHOR AT CENTER OF ANGLE EACH SIDE FOR GREATER A.S.D. DESIGN PRESSURE RATING AND SPAN CONDITIONS. FOR INSTALLATIONS INTO HEADERS USE (2) 1/4"x3/4" TEK SCREW EACH SIDE.

\* 1/4" Ø-20 OR 3/8" Ø-16 MACHINE SCREWS USED JOINTLY W/ 1/4" Ø x 7/8" OR 3/8" Ø x 1 1/4" CALK-IN ANCHORS RESPECTIVELY SHALL BE LEFT TOGETHER W/ ANCHORS AT THE TIME STORM BARS ARE REMOVED. (SEE DET. A).

**TABLE 1**

MAX. A.S.D. DESIGN PRESSURE RATING (p.s.f.)	MAX. SLAT SPAN	"L" MAX. STORM BAR HEIGHT
40.0	3'-0"	8'-0"
	4'-0"	7'-2"
	5'-0"	5'-9"
50.0	3'-0"	7'-7"
	4'-0"	5'-9"
	5'-0"	4'-7"
60.0	3'-0"	6'-4"
	4'-0"	4'-9"
	5'-0"	3'-10"
70.0	3'-0"	5'-5"
	4'-0"	4'-1"
	5'-0"	3'-3"
80.0	3'-0"	4'-9"
	4'-0"	3'-7"
	5'-0"	2'-10"

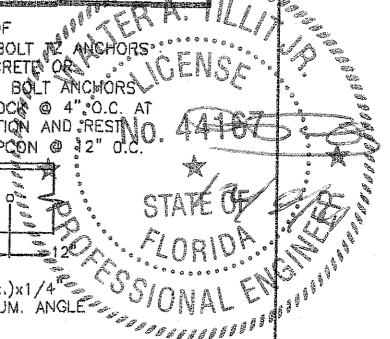

© 2011 TILTECO, INC.

**TILTECO INC.**

TILLIT TESTING & ENGINEERING COMPANY  
6355 N.W. 36th. St., Ste. 305, VIRGINIA GARDENS, FL. 33166  
Phone : (305)871-1530 . Fax : (305)871-1531  
e-mail: tilteco@aol.com

EB-0006719  
WALTER A. TILLIT JR. P.E.  
FLORIDA Lic. # 44167

ASSA/40mm & 60mm BERTHA ROLL-UP  
AMERICAN SHUTTER SYSTEMS ASSOC., INC.  
4268 WESTROADS DRIVE  
WEST PALM BEACH, FL. 33407  
Phone : (877) 999-2772 . Fax : (561) 209-8380

DRAWN BY: L.G./A.G.  
DATE: 12/07/11  
DRAWING No: 11-209  
SHEET 5 OF 14

REV. NO	DESCRIPTION	DATE	REV. No	DESCRIPTION	DATE
1	OLD 08-157	12/07/11	3		
2			4		

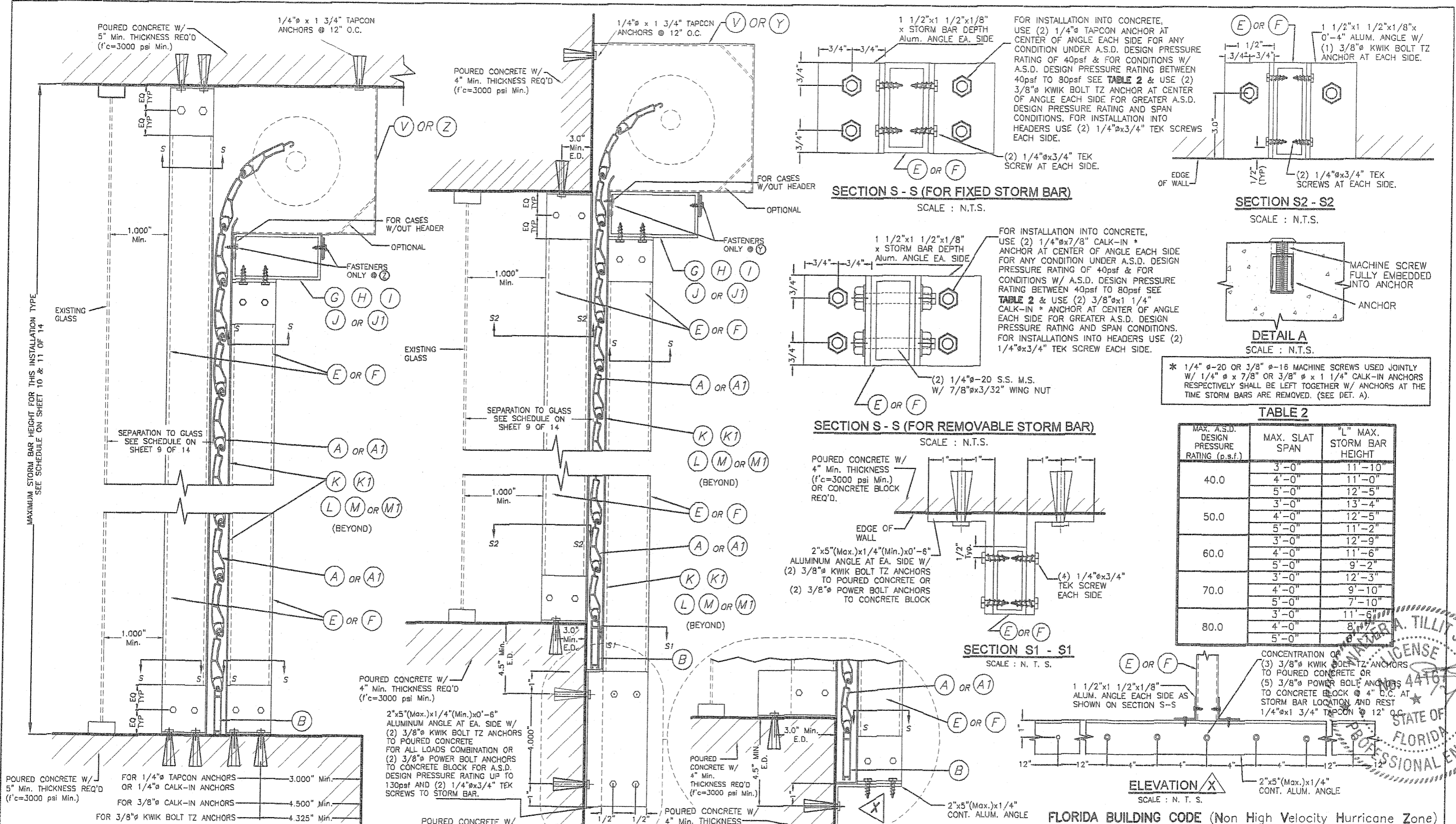

**CEILING & FLOOR MOUNTING: SECTION V-V (2)**  
**INSTALLATION W/ FIXED OR REMOVABLE STORM BARS W/ CONCRETE ANCHORS**  
(SEE SECTION "S" FOR ANCHOR TYPE REQUIREMENT)  
SCALE : N.T.S.

**WALL MOUNTING INSTALLATION: SECTION V-V (1)**  
**W/ FIXED STORM BARS W/ CONCRETE ANCHORS**  
SCALE : N.T.S.

**OPTIONAL STORM BAR CONNECTION**

**SECTION V - V**

© 2011 TILTECO, INC.

**TILTECO INC.**

TILLIT TESTING & ENGINEERING COMPANY  
6355 N.W. 36th St., Ste. 305, VIRGINIA GARDENS, FL 33166  
Phone : (305)871-1530 . Fax : (305)871-1531  
e-mail: tilteco@aol.com  
EB-0006719  
WALTER A. TILLIT Jr. P.E.  
FLORIDA Lic. # 44167

ASSA/40mm & 60mm BERTHA ROLL-UP

AMERICAN SHUTTER SYSTEMS ASSOC., INC.

4268 WESTROADS DRIVE  
WEST PALM BEACH, FL 33407  
Phone : (877) 999-2772 . Fax : (561) 209-8380

DRAWN BY: L.G./A.G.  
DATE: 12/07/11  
DRAWING No: 11-209  
SHEET 5A OF 14

REV. NO	DESCRIPTION	DATE	REV. No	DESCRIPTION	DATE
1	OLD 08-157	12/07/11	3		
2			4		

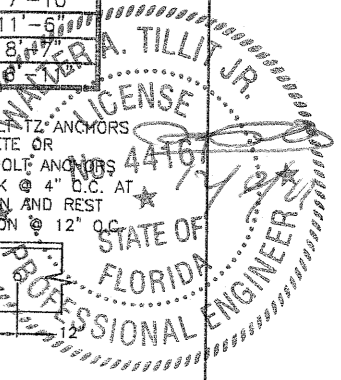

SINGLE SPAN SECTIONS AND DETAILS ARE SIMILAR TO ABOVE SHOWN WITHOUT STORM BAR & HEADERS.



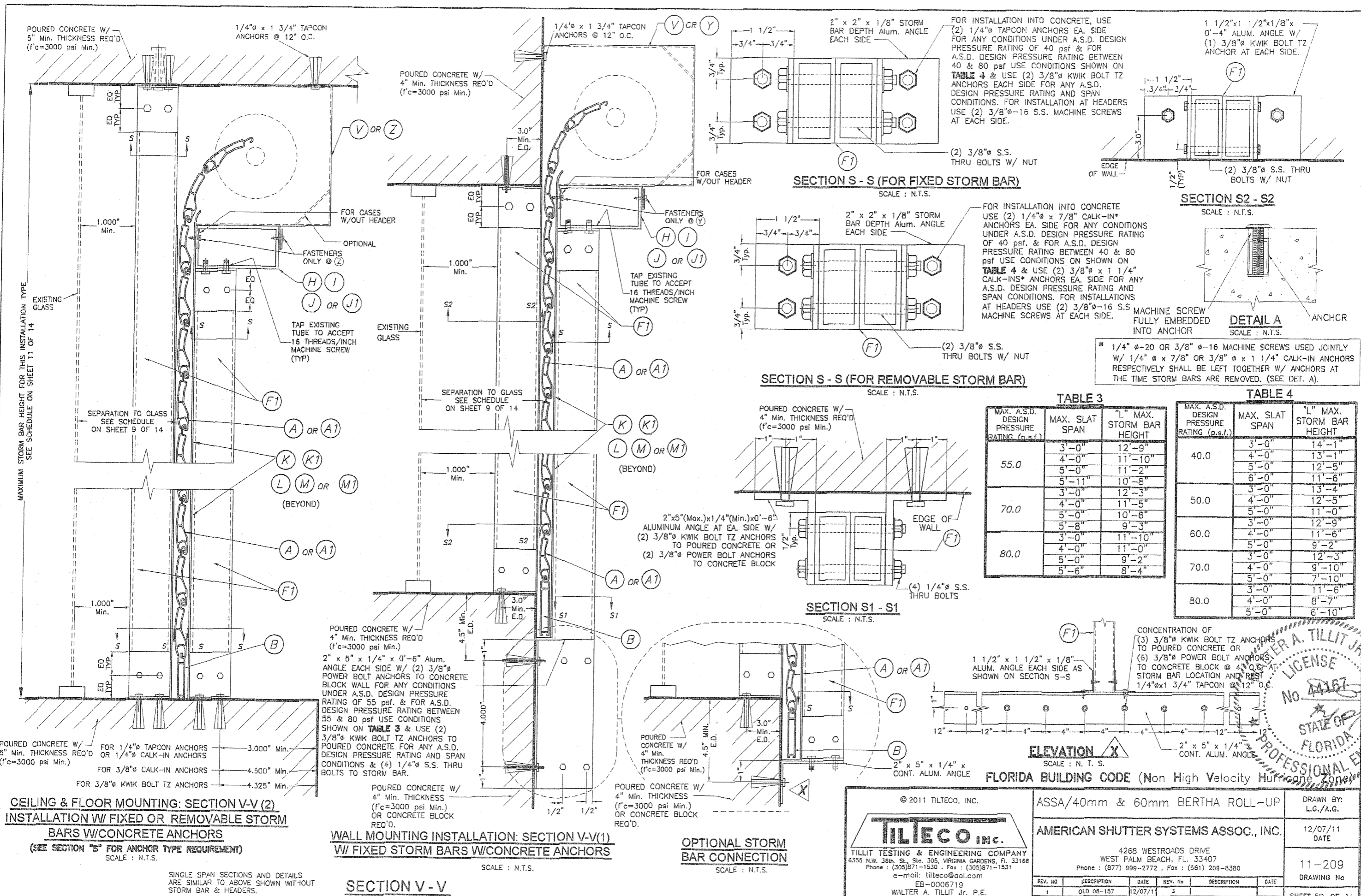

**CEILING & FLOOR MOUNTING: SECTION V-V (2)**  
**INSTALLATION W/ FIXED OR REMOVABLE STORM BARS W/CONCRETE ANCHORS**  
 (SEE SECTION "S" FOR ANCHOR TYPE REQUIREMENT)  
 SCALE : N.T.S.

**WALL MOUNTING INSTALLATION: SECTION V-V(1)**  
**W/ FIXED STORM BARS W/CONCRETE ANCHORS**  
 SCALE : N.T.S.

**OPTIONAL STORM BAR CONNECTION**  
 SCALE : N.T.S.

**SECTION V - V**

**SECTION S - S (FOR FIXED STORM BAR)**  
 SCALE : N.T.S.

**SECTION S - S (FOR REMOVABLE STORM BAR)**  
 SCALE : N.T.S.

**SECTION S1 - S1**  
 SCALE : N.T.S.

**SECTION S2 - S2**  
 SCALE : N.T.S.

**DETAIL A**  
 SCALE : N.T.S.

**TABLE 3**

MAX. A.S.D. DESIGN PRESSURE RATING (p.s.f.)	MAX. SLAT SPAN	"L" MAX. STORM BAR HEIGHT
55.0	3'-0"	12'-9"
	4'-0"	11'-10"
	5'-0"	11'-2"
	5'-11"	10'-8"
70.0	3'-0"	12'-3"
	4'-0"	11'-5"
	5'-0"	10'-6"
	5'-8"	9'-3"
80.0	3'-0"	11'-10"
	4'-0"	11'-0"
	5'-0"	9'-2"
	5'-6"	8'-4"

**TABLE 4**

MAX. A.S.D. DESIGN PRESSURE RATING (p.s.f.)	MAX. SLAT SPAN	"L" MAX. STORM BAR HEIGHT
40.0	3'-0"	14'-1"
	4'-0"	13'-1"
	5'-0"	12'-5"
	6'-0"	11'-6"
50.0	3'-0"	13'-4"
	4'-0"	12'-5"
	5'-0"	11'-0"
	5'-8"	10'-0"
60.0	3'-0"	12'-9"
	4'-0"	11'-6"
	5'-0"	9'-2"
	5'-8"	8'-2"
70.0	3'-0"	12'-3"
	4'-0"	9'-10"
	5'-0"	7'-10"
	5'-8"	7'-10"
80.0	3'-0"	11'-6"
	4'-0"	8'-7"
	5'-0"	6'-10"
	5'-8"	6'-10"

\* 1/4" Ø-20 OR 3/8" Ø-16 MACHINE SCREWS USED JOINTLY W/ 1/4" Ø x 7/8" OR 3/8" Ø x 1 1/4" CALK-IN ANCHORS RESPECTIVELY SHALL BE LEFT TOGETHER W/ ANCHORS AT THE TIME STORM BARS ARE REMOVED. (SEE DET. A).

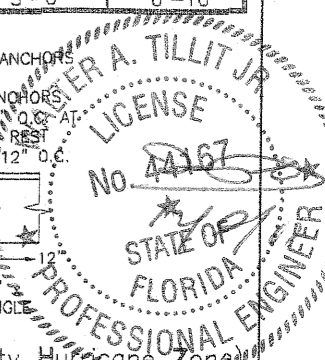

**ELEVATION X**  
 SCALE : N. T. S.

**FLORIDA BUILDING CODE (Non High Velocity Hurricane Zone)**

© 2011 TILTECO, INC.

**TILTECO INC.**

TILLIT TESTING & ENGINEERING COMPANY  
 6355 N.W. 36th St., Ste. 305, VIRGINIA GARDENS, FL. 33168  
 Phone : (305)871-1530 . Fax : (305)871-1531  
 e-mail: tilteco@aol.com  
 EB-0006719  
 WALTER A. TILLIT Jr. P.E.  
 FLORIDA Lic. # 44167

ASSA/40mm & 60mm BERTHA ROLL-UP  
 AMERICAN SHUTTER SYSTEMS ASSOC., INC.  
 4268 WESTROADS DRIVE  
 WEST PALM BEACH, FL. 33407  
 Phone : (877) 999-2772 . Fax : (561) 209-8380

DRAWN BY: L.G./A.G.  
 DATE: 12/07/11  
 11-209  
 DRAWING No

REV. NO	DESCRIPTION	DATE	REV. No	DESCRIPTION	DATE
1	OLD 08-157	12/07/11	3		
2			4		

SHEET 5B OF 14

SINGLE SPAN SECTIONS AND DETAILS ARE SIMILAR TO ABOVE SHOWN WIT-OUT STORM BAR & HEADERS.

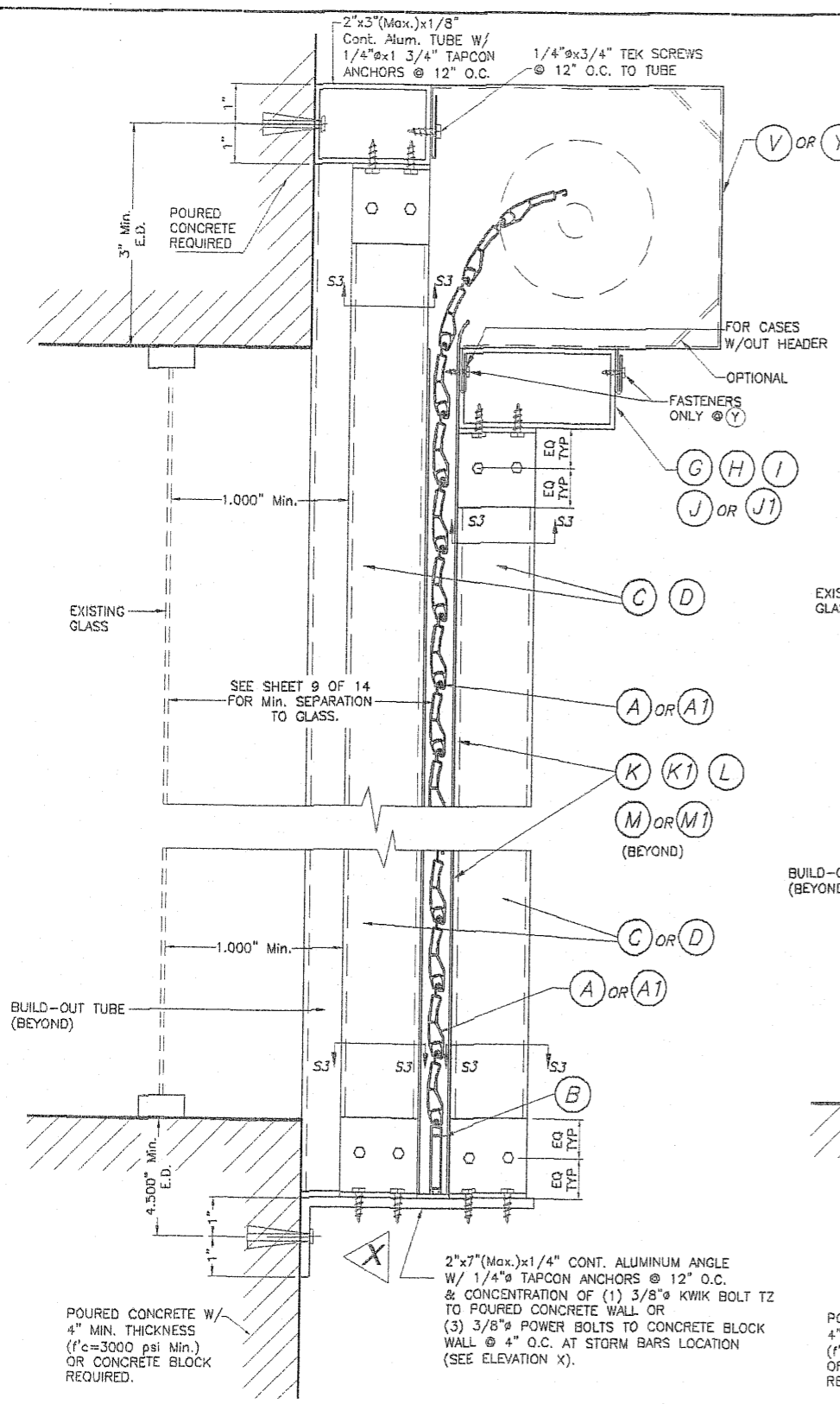

**CASE I**

**FIXED STORM BAR CONNECTION AT BUILD-OUT  
INSTALLATIONS W/SHEET METAL SCREWS OR MACHINE SCREWS**

SCALE : N.T.S.

**SECTION V-V (3)**

NOTE:  
SINGLE SPAN SECTIONS AND DETAILS  
ARE SIMILAR TO ABOVE SHOWN WITHOUT  
STORM BAR & HEADERS.

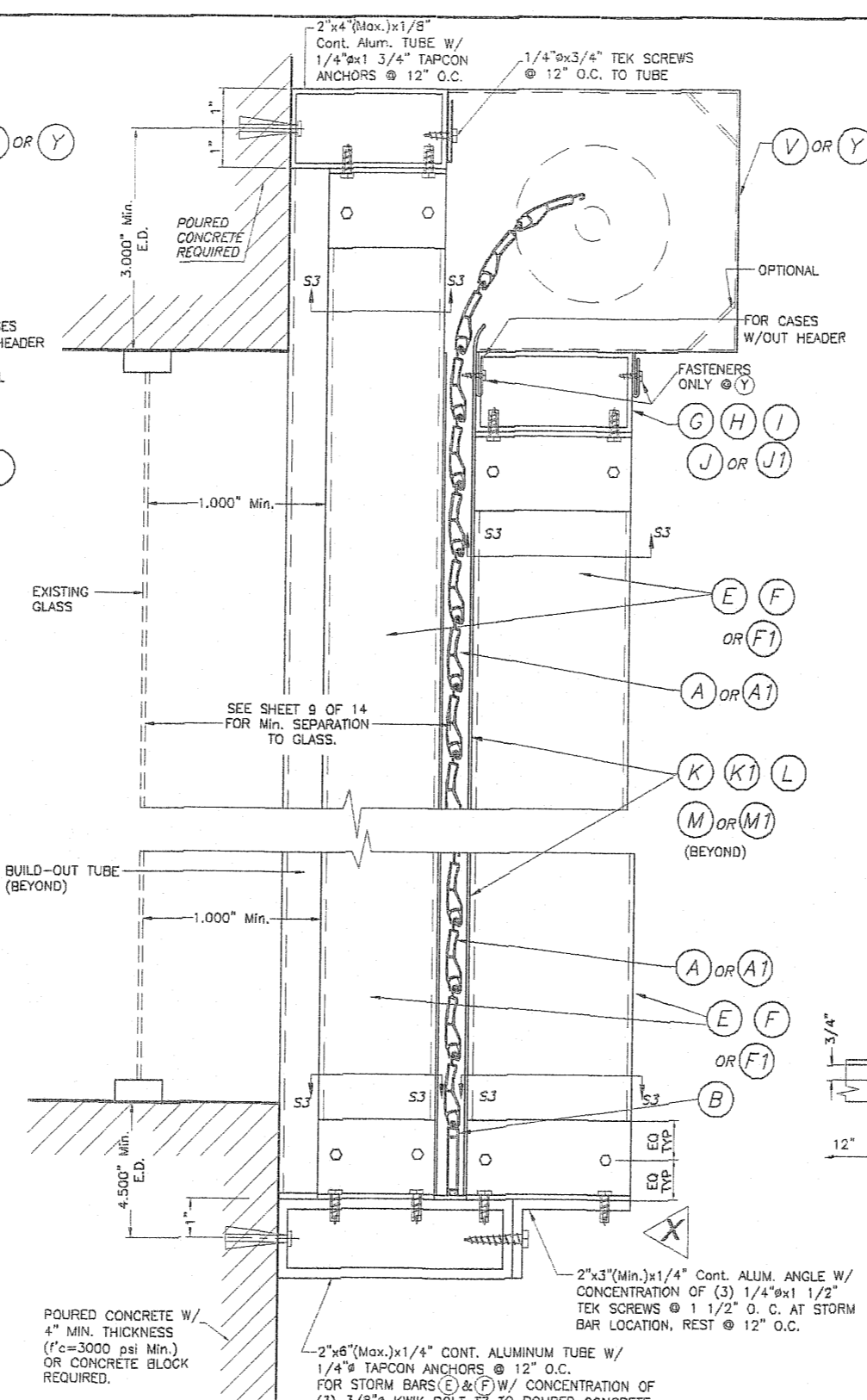

**CASE II**

**FLORIDA BUILDING CODE (Non High Velocity Hurricane Zone)**

© 2011 TILTECO, INC.

**TILTECO inc.**

TILLIT TESTING & ENGINEERING COMPANY  
6355 N.W. 36th St., Ste. 305, VIRGINIA GARDENS, FL 33166  
Phone : (305) 871-1530 . Fax : (305) 871-1531  
e-mail: tilteco@aol.com  
EB-0006719  
WALTER A. TILLIT Jr. P.E.  
FLORIDA Lic. # 44167

ASSA/40mm & 60mm BERTHA ROLL-UP

AMERICAN SHUTTER SYSTEMS ASSOC., INC.

4268 WESTROADS DRIVE  
WEST PALM BEACH, FL. 33407  
Phone : (877) 999-2772 . Fax : (561) 209-8380

REV. NO	DESCRIPTION	DATE	REV. No	DESCRIPTION	DATE
1	OLD 08-157	12/07/11	3		
2			4		

DRAWN BY:  
L.G./A.G.

12/07/11  
DATE

11-209  
DRAWING No

SHEET 6 OF 14

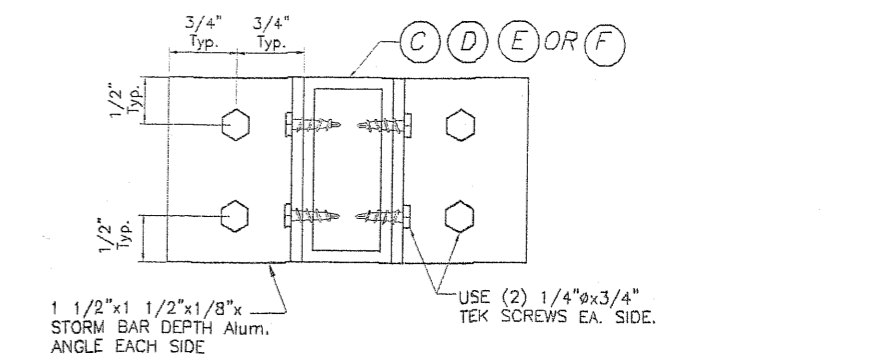

**SECTION S3 - S3**  
SCALE : N.T.S.

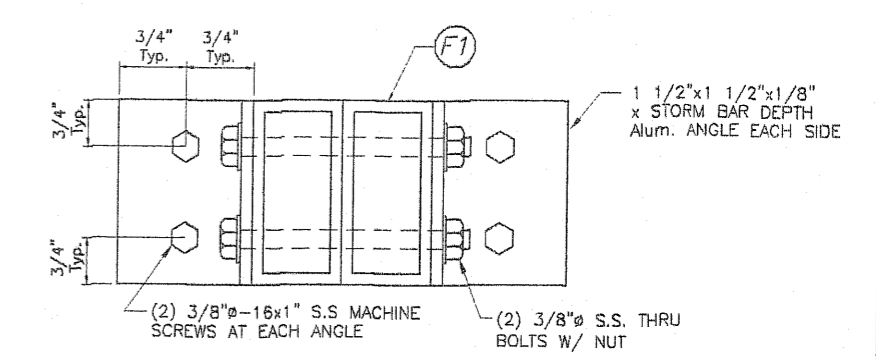

**SECTION S3 - S3**  
SCALE : N.T.S.

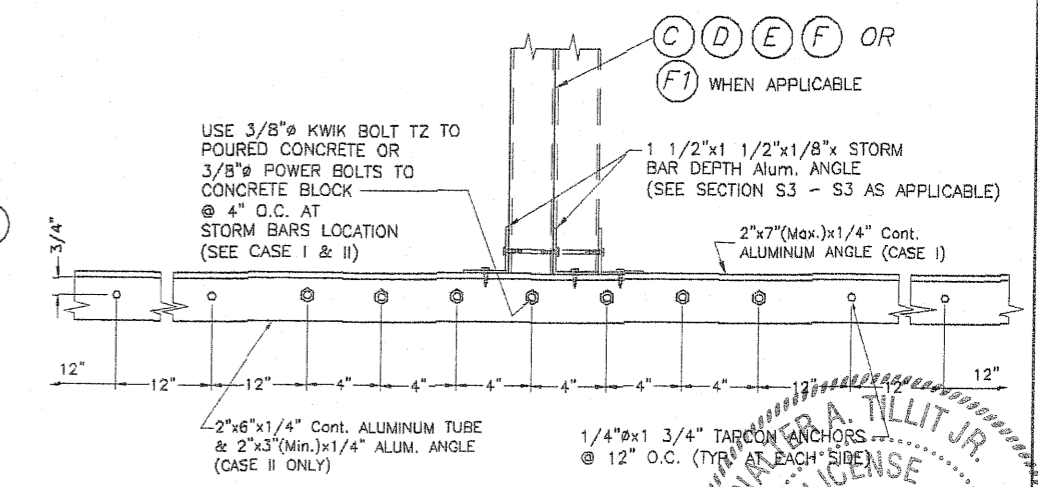

**ELEVATION X**  
SCALE : N.T.S.

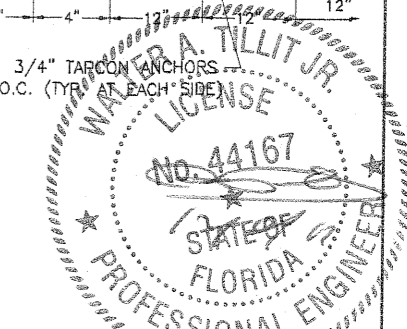

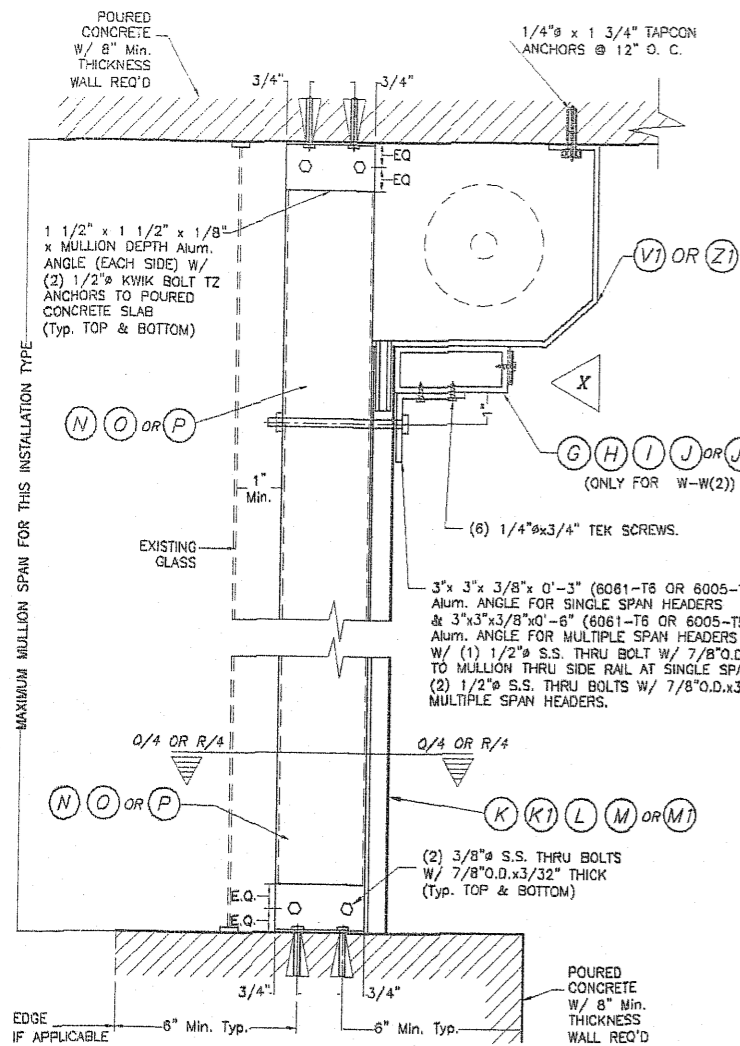

**FLOOR/CEILING MOUNTING :**  
**SECTION W-W (1), W/O HEADER**  
**SECTION W-W (2), W/HEADER**  
 SCALE : 1/8" = 1"

**\*\* NOTE:**  
 USE (J1) HEADER ONLY FOR SINGLE SPAN INSTALLATIONS, IF MULTIPLE SPANS ARE NEEDED, THEN USE DOUBLE MULLIONS W/ 3" GAP IN BETWEEN THEM SELVES FOR EACH INDIVIDUAL SPAN.

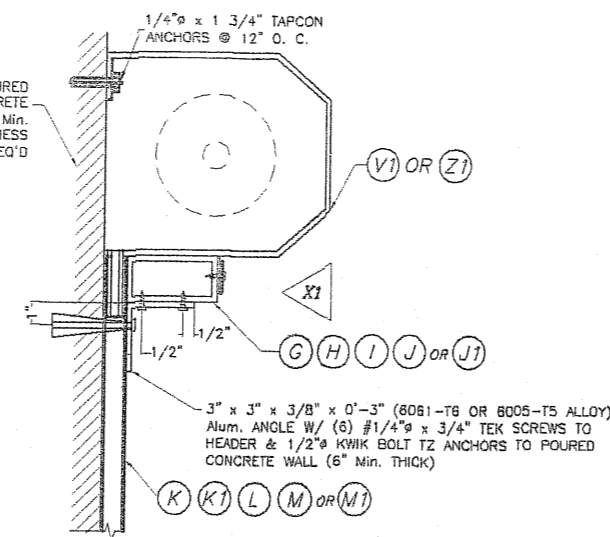

**ALTERNATIVE 1**  
**WALL MOUNTING : SECTION W-W (3)**  
 SCALE : 1/8" = 1"

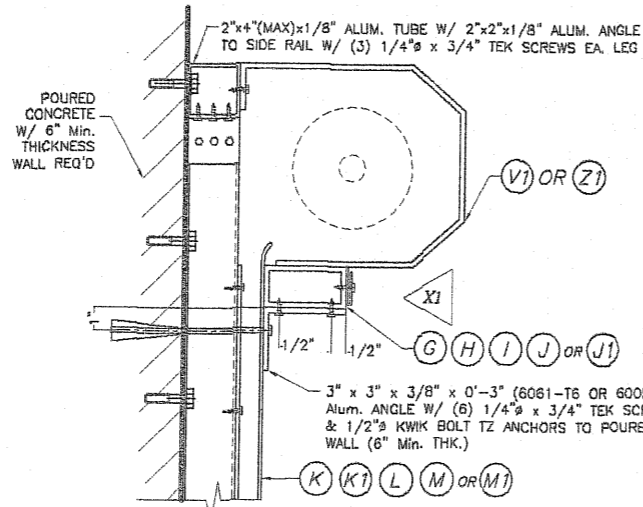

**ALTERNATIVE 2**  
**WALL MOUNTING : SECTION W-W (3)**  
 SCALE : 1/8" = 1"

**NOTE:**  
 INSTALLATION DETAILS SHOWN ON ALTERNATIVES 1 & 2 ARE VALID FOR STORM BAR HEIGHTS AND SINGLE HEADER SPAN CONDITIONS FOR A.S.D. DESIGN PRESSURE RATING UP TO 120 psf.

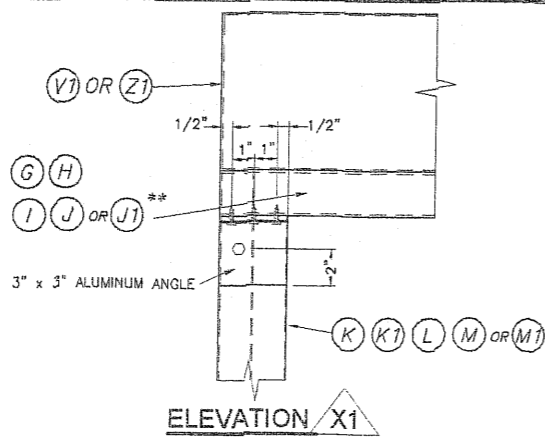

**ELEVATION X1**  
 SCALE : 1/8" = 1"  
**TYPICAL HEADER CONNECTION AT ENDS:**  
**SECTION W-W**

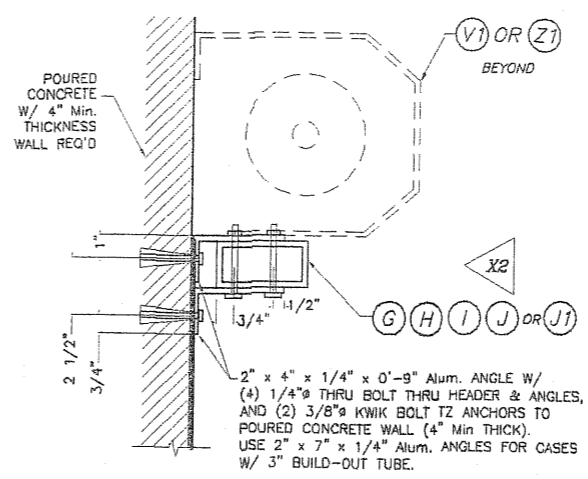

**ALTERNATIVE 3**  
**WALL MOUNTING : SECTION W-W (3)**  
 SCALE : 1/8" = 1"

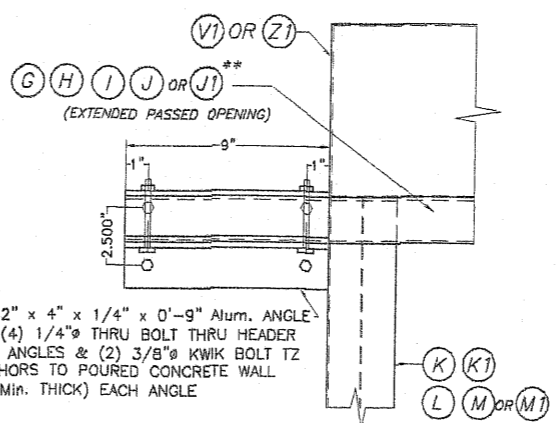

**ELEVATION X2**  
 SCALE : 1/8" = 1"  
**TYPICAL HEADER CONNECTION AT ENDS:**  
**SECTION W-W**

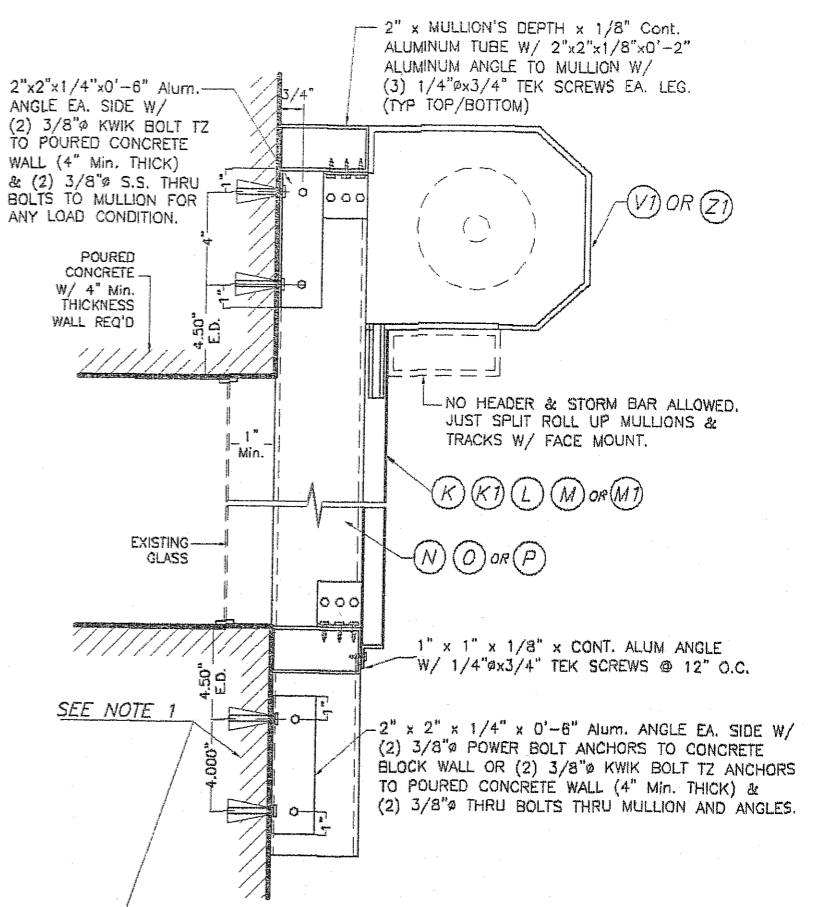

**WALL MOUNTING : MULLION CONNECTION**  
**AT TOP & BOTTOM : SECTION W-W (1)**  
 SCALE : 1/8" = 1"

**NOTE 1:**  
 EXISTING WALL MAY BE POURED CONCRETE OR CONCRETE BLOCK FOR A.S.D. DESIGN PRESSURE RATING UP TO 80.0 psf W/ 9'-0" Max. MULLION HEIGHT AND 5'-0" Max. MULLION SPACING. SHALL BE 4" Min. THICK POURED CONCRETE FOR GREATER LOADS.

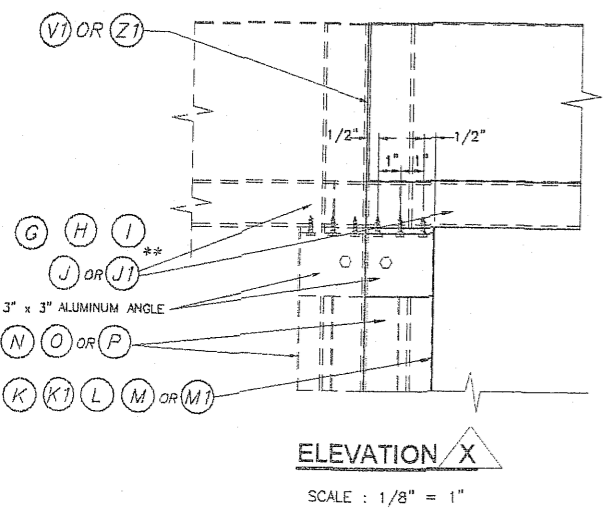

**ELEVATION X**  
 SCALE : 1/8" = 1"

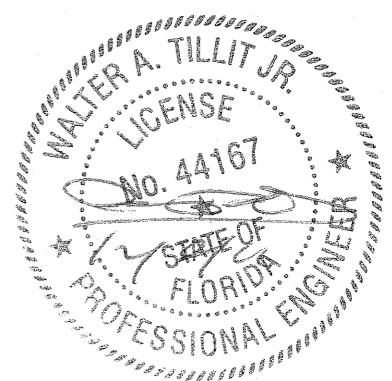

FLORIDA BUILDING CODE (Non High Velocity Hurricane Zone)

© 2011 TILTECO, INC.		ASSA/40mm & 60mm BERTHA ROLL-UP		DRAWN BY: L.G./A.G.	
TILLIT TESTING & ENGINEERING COMPANY 6355 N.W. 36th St., Ste. 305, VIRGINIA GARDENS, FL. 33166 Phone : (305) 871-1530 . Fax : (305) 871-1531 e-mail: tilteco@aol.com EB-0006719 WALTER A. TILLIT Jr. P.E. FLORIDA Lic. # 44167		AMERICAN SHUTTER SYSTEMS ASSOC., INC.		12/07/11 DATE	
		4268 WESTROADS DRIVE WEST PALM BEACH, FL. 33407 Phone : (877) 999-2772 . Fax : (561) 209-8380		11-209 DRAWING No	
REV. NO	DESCRIPTION	DATE	REV. No	DESCRIPTION	DATE
1	OLD 08-157	12/07/11	3		
2			4		





**SLAT PERFORMANCE CHART MAXIMUM A.S.D. DESIGN PRESSURE RATING (psf) AND CORRESPONDING MAXIMUM SLAT SPAN "L" FOR TYPE 1 & 2 SLAT**

(USE MAXIMUM VALUES BETWEEN POSITIVE AND NEGATIVE LOAD)

SLAT TYPE	A		A1	
	MAXIMUM SLAT SPAN	MINIMUM SEPARATION TO GLASS	MAXIMUM SLAT SPAN	MINIMUM SEPARATION TO GLASS
	SINGLE & MULTIPLE UNIT *	SINGLE & MULTIPLE UNIT *	SINGLE & MULTIPLE UNIT *	SINGLE & MULTIPLE UNIT *
25.0	7'-8"	1"	5'-2"	1"
30.0	7'-4"	1"	5'-1"	1"
35.0	7'-0"	1"	4'-10"	1"
40.0	6'-8"	1"	4'-6"	1"
45.0	6'-6"	1"	4'-3"	1"
50.0	6'-3"	1"	4'-0"	1"
55.0	6'-1"	1"	3'-10"	1"
60.0	6'-0"	1"	3'-8"	1"
65.0	5'-10"	1"	3'-6"	1"
70.0	5'-9"	1"	3'-5"	1"
75.0	5'-7"	1"	3'-3"	1"
80.0	5'-6"	1"	3'-2"	1"
85.0	5'-5"	1"	3'-1"	1"
90.0	5'-4"	1"	3'-0"	1"
95.0	5'-3"	1"	2'-11"	1"
100.0	5'-2"	1"	2'-10"	1"
105.0	5'-1"	1"	-	-
110.0	5'-0"	1"	-	-
115.0	4'-11"	1"	-	-
120.0	4'-10"	1"	-	-
125.0	4'-9"	1"	-	-
130.0	4'-7"	1"	-	-
135.0	4'-6"	1"	-	-
140.0	4'-5"	1"	-	-
145.0	4'-4"	1"	-	-
150.0	4'-4"	1"	-	-
155.0	4'-3"	1"	-	-
160.0	4'-2"	1"	-	-
165.0	4'-1"	1"	-	-
170.0	4'-0"	1"	-	-
175.0	4'-0"	1"	-	-
180.0	3'-11"	1"	-	-
185.0	3'-10"	1"	-	-
190.0	3'-10"	1"	-	-
195.0	3'-9"	1"	-	-

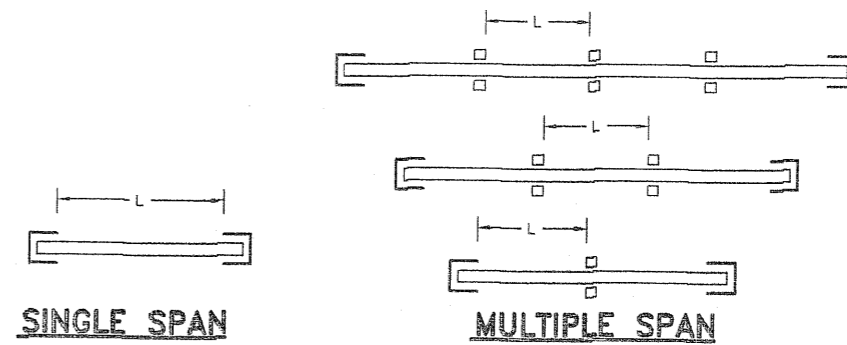

**SPAN LAYOUT**

\* MINIMUM SEPARATION TO GLASS FOR SINGLE AND MULTIPLE UNITS SHALL BE MEASURED FROM BACK OF SLAT TO GLASS.

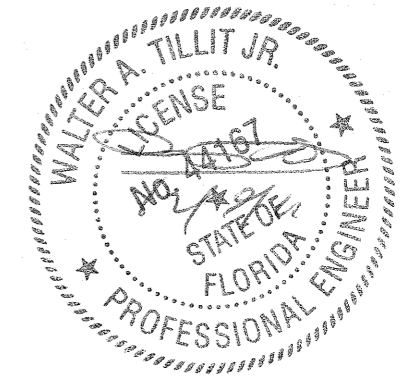

FLORIDA BUILDING CODE (Non High Velocity Hurricane Zone)

© 2011 TILTECO, INC.		ASSA/40mm & 60mm BERTHA ROLL-UP		DRAWN BY: L.G./A.G.	
TILTECO inc. TILLIT TESTING & ENGINEERING COMPANY 6355 N.W. 36th St., Ste. 305, VIRGINIA GARDENS, FL 33168 Phone : (305)871-1530 . Fax : (305)871-1531 e-mail: tilteco@aol.com EB-0006719 WALTER A. TILLIT Jr. P.E. FLORIDA Lic. # 44167		AMERICAN SHUTTER SYSTEMS ASSOC., INC.		12/07/11 DATE	
		4268 WESTROADS DRIVE WEST PALM BEACH, FL. 33407 Phone : (877) 999-2772 . Fax : (561) 209-8380		11-209 DRAWING No	
REV. NO	DESCRIPTION	DATE	REV. No	DESCRIPTION	DATE
1	OLD 08-157	12/07/11	3		
2			4		

**STORM BAR LOADING CHART**  
**MAXIMUM A.S.D. DESIGN PRESSURE RATING (p. s. f.) AND CORRESPONDING MAXIMUM SPAN "L"**  
**FOR A GIVEN TYPE OF STORM BAR AND STORM BAR SPACING.**  
 (USE MAXIMUM VALUES BETWEEN POSITIVE AND NEGATIVE LOAD)

**MAX. SPAN FOR STORM BARS W/REGULAR CONCRETE ANCHORS**

MAXIMUM A.S.D. DESIGN PRESSURE RATING (p.s.f.)	TYPE 1 STORM BAR 2" x 2" x 1/4" (C)					TYPE 2 STORM BAR 2" x 3" x 1/8" (D)					TYPE 3 STORM BAR 2" x 4" x 1/8" (E)				
	* STORM BAR SPACING					* STORM BAR SPACING					* STORM BAR SPACING				
	< 3'-0"	3' TO 4'	4' TO 5'	5' TO 6'	6' TO 6.5'	< 3'-0"	3' TO 4'	4' TO 5'	5' TO 6'	6' TO 6.5'	< 3'-0"	3' TO 4'	4' TO 5'	5' TO 6'	6' TO 6.5'
40 OR LESS	7'-7"	7'-1"	6'-9"	6'-2"	5'-11"	8'-0"	7'-9"	6'-11"	6'-4"	6'-1"	10'-0"	9'-6"	8'-6"	7'-9"	7'-5"
45	7'-5"	6'-11"	6'-4"	5'-10"	5'-7"	8'-0"	7'-4"	6'-7"	6'-0"	5'-9"	9'-11"	8'-11"	8'-0"	7'-4"	7'-0"
50	7'-3"	6'-9"	6'-0"	5'-6"	5'-4"	8'-0"	7'-0"	6'-3"	5'-8"	5'-6"	9'-8"	8'-6"	7'-7"	6'-11"	6'-8"
55	7'-0"	6'-5"	5'-9"	5'-3"	—	7'-8"	6'-8"	5'-6"	5'-6"	—	9'-4"	8'-1"	7'-3"	6'-7"	—
60	6'-11"	6'-2"	5'-6"	5'-0"	—	7'-4"	6'-4"	5'-8"	5'-2"	—	8'-11"	7'-9"	6'-11"	6'-4"	—
65	6'-9"	5'-11"	5'-4"	4'-10"	—	7'-1"	6'-1"	5'-5"	5'-0"	—	8'-7"	7'-5"	6'-8"	6'-1"	—
70	6'-7"	5'-8"	5'-1"	4'-8"	—	6'-10"	5'-11"	5'-3"	4'-10"	—	8'-3"	7'-2"	6'-5"	5'-10"	—
75	6'-4"	5'-6"	4'-11"	4'-6"	—	6'-7"	5'-8"	5'-1"	4'-8"	—	8'-0"	6'-11"	6'-2"	5'-8"	—
80	6'-2"	5'-4"	4'-9"	4'-4"	—	6'-4"	5'-6"	4'-11"	4'-6"	—	7'-9"	6'-9"	6'-0"	5'-6"	—
85	6'-0"	5'-2"	4'-8"	4'-3"	—	6'-2"	5'-4"	4'-9"	4'-4"	—	7'-6"	6'-6"	5'-10"	5'-4"	—
90	5'-10"	5'-0"	4'-6"	4'-1"	—	6'-0"	5'-2"	4'-8"	4'-3"	—	7'-4"	6'-4"	5'-8"	5'-2"	—
95	5'-8"	4'-11"	4'-5"	4'-0"	—	5'-10"	5'-1"	4'-6"	4'-1"	—	7'-1"	6'-2"	5'-6"	5'-0"	—
100	5'-6"	4'-9"	4'-3"	3'-11"	—	5'-8"	4'-11"	4'-5"	4'-0"	—	6'-11"	6'-0"	5'-4"	4'-11"	—
105	5'-5"	4'-8"	4'-2"	3'-10"	—	5'-7"	4'-10"	4'-4"	3'-11"	—	6'-9"	5'-10"	5'-3"	4'-9"	—
110	5'-3"	4'-7"	4'-1"	—	—	5'-5"	4'-8"	4'-2"	—	—	6'-7"	5'-9"	5'-1"	—	—
115	5'-2"	4'-5"	4'-0"	—	—	5'-4"	4'-7"	4'-1"	—	—	6'-6"	5'-7"	5'-0"	—	—
120	5'-0"	4'-4"	3'-11"	—	—	5'-2"	4'-6"	4'-0"	—	—	6'-4"	5'-6"	4'-11"	—	—
125	4'-11"	4'-3"	3'-10"	—	—	5'-1"	4'-5"	3'-11"	—	—	6'-2"	5'-4"	4'-10"	—	—
130	4'-10"	4'-2"	3'-9"	—	—	5'-0"	4'-4"	3'-10"	—	—	6'-1"	5'-3"	4'-9"	—	—
135	4'-9"	4'-1"	3'-8"	—	—	4'-11"	4'-3"	3'-9"	—	—	6'-0"	5'-2"	4'-7"	—	—
140	4'-8"	4'-0"	3'-7"	—	—	4'-10"	4'-2"	3'-9"	—	—	5'-10"	5'-1"	4'-6"	—	—
145	4'-7"	4'-0"	3'-7"	—	—	4'-9"	4'-1"	3'-8"	—	—	5'-9"	5'-0"	4'-6"	—	—
150	4'-6"	3'-11"	3'-6"	—	—	4'-8"	4'-0"	3'-7"	—	—	5'-8"	4'-11"	4'-5"	—	—
155	4'-5"	3'-10"	3'-5"	—	—	4'-7"	3'-11"	3'-6"	—	—	5'-7"	4'-10"	4'-4"	—	—
160	4'-4"	3'-9"	3'-4"	—	—	4'-6"	3'-11"	3'-6"	—	—	5'-6"	4'-9"	4'-3"	—	—
165	4'-3"	3'-9"	3'-4"	—	—	4'-5"	3'-10"	3'-5"	—	—	5'-5"	4'-8"	4'-2"	—	—
170	4'-3"	3'-8"	—	—	—	4'-4"	3'-9"	—	—	—	5'-4"	4'-7"	—	—	—
175	4'-2"	3'-7"	—	—	—	4'-4"	3'-9"	—	—	—	5'-3"	4'-6"	—	—	—
180	4'-1"	3'-7"	—	—	—	4'-3"	3'-8"	—	—	—	5'-2"	4'-6"	—	—	—
185	4'-1"	3'-6"	—	—	—	4'-2"	3'-7"	—	—	—	5'-1"	4'-5"	—	—	—
190	4'-0"	3'-6"	—	—	—	4'-1"	3'-7"	—	—	—	5'-0"	4'-4"	—	—	—
195	3'-11"	3'-5"	—	—	—	4'-1"	3'-6"	—	—	—	5'-0"	4'-4"	—	—	—

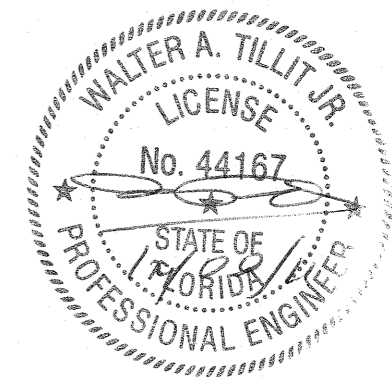

FLORIDA BUILDING CODE (Non High Velocity Hurricane Zone)

\* STORM BAR SPACING SHALL BE SUCH THAT MAXIMUM SLAT SPAN SHALL NOT BE EXCEEDED.

© 2011 TILTECO, INC.		ASSA/40mm & 60mm BERTHA ROLL-UP		DRAWN BY: L.G./A.G.	
 TILTECO INC. TILLIT TESTING & ENGINEERING COMPANY 6355 N.W. 36th St., Ste. 305, VIRGINIA GARDENS, FL 33166 Phone: (305)871-1530 Fax: (305)871-1531 e-mail: tilteco@aol.com		AMERICAN SHUTTER SYSTEMS ASSOC., INC.		12/07/11 DATE	
EB-0006719 WALTER A. TILLIT Jr. P.E. FLORIDA Lic. # 44167		4268 WESTROADS DRIVE WEST PALM BEACH, FL. 33407 Phone: (877) 999-2772 Fax: (561) 209-8380		11-209 DRAWING No	
REV. NO	DESCRIPTION	DATE	REV. No	DESCRIPTION	DATE
1	OLD 08-157	12/07/11	3		
2			4		
				SHEET 10 OF 14	

**STORM BAR LOADING CHART**  
**MAXIMUM A.S.D. DESIGN PRESSURE RATING (p. s. f.) AND CORRESPONDING MAXIMUM SPAN "L"**  
**FOR A GIVEN TYPE OF STORM BAR AND STORM BAR SPACING.**  
 (USE MAXIMUM VALUES BETWEEN POSITIVE AND NEGATIVE LOAD)

**MAX. SPAN FOR STORM BARS W/REGULAR CONCRETE ANCHORS**

MAXIMUM A.S.D. DESIGN PRESSURE RATING (p.s.f.)	TYPE 4 STORM BAR (F) 2" x 4" x .250"					TYPE 5 STORM BAR (F1) (2) 2" x 4" x .250"				
	* STORM BAR SPACING									
	< 3'-0"	3' TO 4'	4' TO 5'	5' TO 6'	6' TO 6.5'	< 3'-0"	3' TO 4'	4' TO 5'	5' TO 6'	6' TO 6.5'
40 OR LESS	11'-10"	11'-0"	10'-5"	9'-11"	9'-9"	14'-1"	13'-1"	12'-5"	11'-10"	11'-7"
45	11'-6"	10'-8"	10'-1"	9'-8"	9'-4"	13'-8"	12'-9"	12'-0"	11'-6"	11'-3"
50	11'-2"	10'-5"	9'-10"	9'-2"	8'-10"	13'-4"	12'-5"	11'-9"	11'-2"	11'-0"
55	10'-11"	10'-2"	9'-7"	8'-9"	-	13'-0"	12'-1"	11'-5"	10'-11"	-
60	10'-8"	9'-11"	9'-2"	8'-5"	-	12'-9"	11'-10"	11'-2"	10'-8"	-
65	10'-6"	9'-9"	8'-10"	8'-1"	-	12'-6"	11'-7"	11'-0"	10'-6"	-
70	10'-4"	9'-6"	8'-6"	7'-9"	-	12'-3"	11'-5"	10'-9"	10'-4"	-
75	10'-1"	9'-2"	8'-3"	7'-6"	-	12'-0"	11'-2"	10'-7"	10'-1"	-
80	9'-11"	8'-11"	7'-11"	7'-3"	-	11'-10"	11'-0"	10'-5"	9'-11"	-
85	9'-10"	8'-7"	7'-9"	7'-0"	-	11'-8"	10'-10"	10'-3"	9'-10"	-
90	9'-8"	8'-5"	7'-6"	6'-10"	-	11'-6"	10'-8"	10'-1"	9'-8"	-
95	9'-5"	8'-2"	7'-4"	6'-8"	-	11'-4"	10'-7"	10'-0"	9'-5"	-
100	9'-2"	7'-11"	7'-1"	6'-6"	-	11'-2"	10'-5"	9'-10"	9'-2"	-
105	8'-11"	7'-9"	6'-11"	6'-4"	-	11'-1"	10'-4"	9'-9"	8'-11"	-
110	8'-9"	7'-7"	6'-9"	-	-	10'-11"	10'-2"	9'-7"	-	-
115	8'-7"	7'-5"	6'-8"	-	-	10'-10"	10'-1"	9'-4"	-	-
120	8'-5"	7'-3"	6'-6"	-	-	10'-8"	9'-11"	9'-2"	-	-
125	8'-3"	7'-1"	6'-4"	-	-	10'-7"	9'-10"	9'-0"	-	-
130	8'-1"	7'-0"	6'-3"	-	-	10'-6"	9'-9"	8'-10"	-	-
135	7'-11"	6'-10"	6'-1"	-	-	10'-5"	9'-8"	8'-8"	-	-
140	7'-9"	6'-9"	6'-0"	-	-	10'-4"	9'-6"	8'-6"	-	-
145	7'-7"	6'-7"	5'-11"	-	-	10'-2"	9'-4"	8'-4"	-	-
150	7'-6"	6'-6"	5'-10"	-	-	10'-1"	9'-2"	8'-2"	-	-
155	7'-4"	6'-5"	5'-9"	-	-	10'-0"	9'-0"	8'-1"	-	-
160	7'-3"	6'-3"	5'-7"	-	-	9'-11"	8'-11"	7'-11"	-	-
165	7'-2"	6'-2"	5'-6"	-	-	9'-11"	8'-9"	7'-10"	-	-
170	7'-0"	6'-1"	-	-	-	9'-10"	8'-7"	-	-	-
175	6'-11"	6'-0"	-	-	-	9'-9"	8'-6"	-	-	-
180	6'-10"	5'-11"	-	-	-	9'-8"	8'-4"	-	-	-
185	6'-9"	5'-10"	-	-	-	9'-6"	8'-3"	-	-	-
190	6'-8"	5'-9"	-	-	-	9'-5"	8'-2"	-	-	-
195	6'-7"	5'-8"	-	-	-	9'-3"	8'-0"	-	-	-



\* STORM BAR SPACING SHALL BE SUCH THAT MAXIMUM SLAT SPAN SHALL NOT BE EXCEEDED.

FLORIDA BUILDING CODE (Non High Velocity Hurricane Zone)

© 2011 TILTECO, INC.		ASSA/40mm & 60mm BERTHA ROLL-UP		DRAWN BY: L.G./A.G.	
 TILLIT TESTING & ENGINEERING COMPANY 6355 N.W. 36th St., Ste. 305, VIRGINIA GARDENS, FL 33166 Phone : (305)871-1530 . Fax : (305)871-1531 e-mail: tilteco@aol.com		AMERICAN SHUTTER SYSTEMS ASSOC., INC.		12/07/11 DATE	
		4268 WESTROADS DRIVE WEST PALM BEACH, FL. 33407 Phone : (877) 999-2772 . Fax : (561) 209-8380		11-209 DRAWING No	
REV. NO	DESCRIPTION	DATE	REV. No	DESCRIPTION	DATE
1	OLD 08-157	12/07/11	3		
2			4		
			SHEET 11 OF 14		

**HEADER LOADING CHART MAXIMUM A.S.D. DESIGN PRESSURE RATING (psf) AND  
CORRESPONDING MAXIMUM SPAN "L" FOR A GIVEN TYPE OF HEADER.**

(USE MAXIMUM VALUES BETWEEN POSITIVE AND NEGATIVE LOAD)

MAXIMUM A.S.D. DESIGN PRESSURE RATING (p.s.f.)	TYPE 1 HEADER (G) 2" x 3" x 1/8"		TYPE 2 HEADER (H) 2" x 4" x 1/8"			TYPE 3 HEADER (I) 2" x 4" x 1/4"					TYPE 4 HEADER (J) 2" x 6" x 1/8"					TYPE 5 HEADER (J1) 2" x 6" x 1/4"				
	STORM BAR HEIGHT		STORM BAR HEIGHT			STORM BAR HEIGHT					STORM BAR HEIGHT					STORM BAR HEIGHT				
	< 5'-0"	5' TO 7'	< 5'-0"	5' TO 8'	8' TO 10'	< 6'-0"	6' TO 8'	8' TO 10'	10' TO 12'	12' TO 14'	< 6'-0"	6' TO 8'	8' TO 10'	10' TO 12'	12' TO 14'	< 6'-0"	6' TO 8'	8' TO 10'	10' TO 12'	12' TO 14'
40.0 OR LESS	9'-11"	8'-4"	12'-2"	9'-8"	8'-8"	14'-10"	12'-10"	11'-6"	10'-6"	9'-9"	15'-1"	13'-1"	11'-8"	10'-8"	9'-11"	19'-4"	17'-3"	15'-5"	14'-1"	13'-0"
45.0	9'-4"	7'-11"	11'-6"	9'-1"	8'-2"	14'-0"	12'-2"	10'-10"	9'-11"	9'-2"	14'-3"	12'-4"	11'-0"	10'-1"	9'-4"	18'-9"	16'-3"	14'-6"	13'-3"	12'-3"
50.0	8'-10"	7'-6"	10'-11"	8'-8"	7'-9"	13'-4"	11'-6"	10'-4"	9'-5"	8'-8"	13'-6"	11'-8"	10'-6"	9'-7"	8'-10"	17'-9"	15'-5"	13'-9"	12'-7"	11'-8"
55.0	8'-5"	7'-2"	10'-5"	8'-3"	7'-4"	12'-8"	11'-0"	9'-10"	9'-0"	8'-4"	12'-11"	11'-2"	10'-0"	9'-1"	8'-5"	17'-0"	14'-8"	13'-2"	12'-0"	11'-1"
60.0	8'-1"	6'-10"	10'-0"	7'-11"	7'-1"	12'-2"	10'-6"	9'-5"	9'-7"	7'-11"	12'-4"	10'-8"	9'-7"	8'-9"	8'-1"	16'-3"	14'-1"	12'-7"	11'-6"	10'-8"
65.0	7'-9"	6'-7"	9'-7"	7'-7"	6'-9"	11'-8"	10'-1"	9'-0"	8'-3"	7'-8"	11'-10"	10'-3"	9'-2"	8'-5"	7'-9"	15'-7"	13'-6"	12'-1"	11'-0"	10'-3"
70.0	7'-6"	6'-4"	9'-3"	7'-4"	6'-6"	11'-3"	9'-9"	8'-8"	7'-11"	7'-4"	11'-5"	9'-11"	8'-10"	8'-1"	7'-6"	15'-0"	13'-0"	11'-8"	10'-8"	9'-10"
75.0	7'-3"	6'-1"	8'-11"	7'-1"	6'-4"	10'-10"	9'-5"	8'-5"	7'-8"	7'-1"	11'-0"	9'-7"	8'-7"	7'-10"	7'-3"	14'-6"	12'-7"	11'-3"	10'-3"	9'-6"
80.0	7'-0"	5'-11"	8'-8"	6'-10"	6'-1"	10'-6"	9'-1"	8'-2"	7'-5"	6'-11"	10'-8"	9'-3"	8'-3"	7'-7"	7'-0"	14'-1"	12'-2"	10'-11"	9'-11"	9'-2"
85.0	6'-9"	5'-9"	8'-5"	6'-7"	5'-11"	10'-2"	8'-10"	7'-11"	7'-3"	6'-8"	10'-4"	9'-0"	8'-0"	7'-4"	6'-9"	13'-8"	11'-10"	10'-7"	9'-8"	8'-11"
90.0	6'-7"	5'-7"	8'-2"	6'-5"	5'-9"	9'-11"	8'-7"	7'-8"	7'-0"	6'-6"	10'-1"	8'-9"	7'-10"	7'-1"	6'-7"	13'-3"	11'-6"	10'-3"	9'-5"	8'-8"
95.0	6'-5"	5'-5"	7'-11"	6'-3"	5'-7"	9'-8"	8'-4"	7'-6"	6'-10"	6'-4"	9'-10"	8'-6"	7'-7"	6'-11"	6'-5"	12'-11"	11'-2"	10'-0"	9'-2"	8'-5"
100.0	6'-3"	5'-3"	7'-9"	6'-1"	5'-6"	9'-5"	8'-2"	7'-3"	6'-8"	6'-2"	9'-7"	8'-3"	7'-5"	6'-9"	6'-3"	12'-7"	10'-11"	9'-9"	8'-11"	8'-3"
105.0	6'-1"	5'-2"	7'-6"	6'-0"	5'-4"	9'-2"	7'-11"	7'-1"	6'-6"	6'-0"	9'-4"	8'-1"	7'-3"	6'-7"	6'-1"	12'-3"	10'-8"	9'-6"	8'-8"	8'-0"
110.0	6'-0"	5'-1"	7'-4"	5'-10"	5'-2"	9'-0"	7'-9"	6'-11"	6'-4"	5'-10"	9'-1"	7'-11"	7'-1"	6'-5"	6'-0"	12'-0"	10'-5"	9'-3"	8'-6"	7'-10"
115.0	5'-10"	4'-11"	7'-2"	5'-8"	5'-1"	8'-9"	7'-7"	6'-9"	6'-2"	5'-9"	8'-11"	7'-9"	6'-11"	6'-4"	5'-10"	11'-9"	10'-2"	9'-1"	8'-4"	7'-8"
120.0	5'-9"	4'-10"	7'-1"	5'-7"	5'-0"	8'-7"	7'-5"	6'-8"	6'-1"	5'-7"	8'-9"	7'-7"	6'-9"	6'-2"	5'-9"	11'-6"	9'-11"	8'-11"	8'-1"	7'-6"
125.0	5'-7"	4'-9"	6'-11"	5'-6"	4'-11"	8'-5"	7'-3"	6'-6"	5'-11"	5'-6"	8'-7"	7'-5"	6'-7"	6'-1"	5'-7"	11'-3"	9'-9"	8'-9"	7'-11"	7'-4"
130.0	5'-6"	4'-8"	6'-9"	5'-4"	4'-9"	8'-3"	7'-2"	6'-5"	5'-10"	5'-5"	8'-5"	7'-3"	6'-6"	5'-11"	5'-6"	11'-0"	9'-7"	8'-7"	7'-10"	7'-3"
135.0	5'-5"	4'-7"	6'-8"	5'-3"	4'-8"	8'-1"	7'-0"	6'-3"	5'-9"	5'-4"	8'-3"	7'-1"	6'-4"	5'-10"	5'-5"	10'-10"	9'-5"	8'-5"	7'-8"	7'-1"

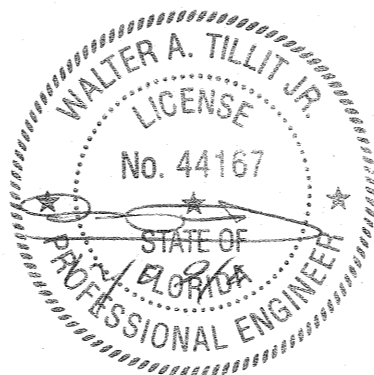

FLORIDA BUILDING CODE (Non High Velocity Hurricane Zone)

© 2011 TILTECO, INC.		ASSA/40mm & 60mm BERTHA ROLL-UP		DRAWN BY: L.G./A.G.	
 TILLIT TESTING & ENGINEERING COMPANY 6355 N.W. 36th St., Ste. 305, VIRGINIA GARDENS, FL 33168 Phone: (305)871-1530 . Fax: (305)871-1531 e-mail: tilteco@aol.com		AMERICAN SHUTTER SYSTEMS ASSOC., INC. 4268 WESTROADS DRIVE WEST PALM BEACH, FL 33407 Phone: (877) 999-2772 . Fax: (561) 209-8380		12/07/11 DATE	
EB-0006719 WALTER A. TILLIT Jr. P.E. FLORIDA Lic. # 44167		11-209 DRAWING No		11-209 DRAWING No	
REV. NO	DESCRIPTION	DATE	REV. NO	DESCRIPTION	DATE
1	OLD 08-157	12/07/11	3		
2			4		
SHEET 12 OF 14					



**HEADER LOADING CHART MAXIMUM A.S.D. DESIGN PRESSURE RATING (psf) AND  
CORRESPONDING MAXIMUM SPAN "L" FOR A GIVEN TYPE OF HEADER.**

(USE MAXIMUM VALUES BETWEEN POSITIVE AND NEGATIVE LOAD)

MAXIMUM A.S.D. DESIGN PRESSURE RATING (p.s.f.)	TYPE 1 HEADER (G) 2" x 3" x 1/8"		TYPE 2 HEADER (H) 2" x 4" x 1/8"			TYPE 3 HEADER (I) 2" x 4" x 1/4"					TYPE 4 HEADER (J) 2" x 6" x 1/8"					TYPE 5 HEADER (J1) 2" x 6" x 1/4"				
	STORM BAR HEIGHT		STORM BAR HEIGHT			STORM BAR HEIGHT					STORM BAR HEIGHT					STORM BAR HEIGHT				
	< 5'-0"	5' TO 7'	< 5'-0"	5' TO 8'	8' TO 10'	< 6'-0"	6' TO 8'	8' TO 10'	10' TO 12'	12' TO 14'	< 6'-0"	6' TO 8'	8' TO 10'	10' TO 12'	12' TO 14'	< 6'-0"	6' TO 8'	8' TO 10'	10' TO 12'	12' TO 14'
140.0	5'-3"	4'-6"	6'-6"	5'-2"	4'-7"	7'-11"	6'-11"	6'-2"	5'-7"	5'-2"	8'-1"	7'-0"	6'-3"	5'-9"	5'-3"	10'-8"	9'-2"	8'-3"	7'-6"	6'-11"
145.0	5'-2"	4'-5"	6'-5"	5'-1"	4'-6"	7'-10"	6'-9"	6'-1"	5'-6"	5'-1"	7'-11"	6'-10"	6'-2"	5'-7"	5'-2"	10'-5"	9'-1"	8'-1"	7'-5"	6'-10"
150.0	5'-1"	4'-4"	6'-4"	5'-0"	4'-6"	7'-8"	6'-8"	5'-11"	5'-5"	5'-0"	7'-10"	6'-9"	6'-1"	5'-6"	5'-1"	10'-3"	8'-11"	7'-11"	7'-3"	6'-9"
155.0	5'-0"	4'-3"	6'-2"	4'-11"	4'-5"	7'-7"	6'-6"	5'-10"	5'-4"	4'-11"	7'-8"	6'-8"	5'-11"	5'-5"	5'-0"	10'-1"	8'-9"	7'-10"	7'-2"	6'-7"
160.0	4'-11"	4'-2"	6'-1"	4'-10"	4'-4"	7'-5"	6'-5"	5'-9"	5'-3"	4'-10"	7'-7"	6'-6"	5'-10"	5'-4"	4'-11"	9'-11"	8'-7"	7'-8"	7'-0"	6'-6"
165.0	4'-10"	4'-1"	6'-0"	4'-9"	4'-3"	7'-4"	6'-4"	5'-8"	5'-2"	4'-10"	7'-5"	6'-5"	5'-9"	5'-3"	4'-10"	9'-10"	8'-6"	7'-7"	6'-11"	6'-5"
170.0	4'-10"	4'-1"	5'-11"	4'-8"	4'-2"	7'-3"	6'-3"	5'-7"	5'-1"	4'-9"	7'-4"	6'-4"	5'-8"	5'-2"	4'-10"	9'-8"	8'-4"	7'-6"	6'-10"	6'-4"
175.0	4'-9"	4'-0"	5'-10"	4'-7"	4'-2"	7'-1"	6'-2"	5'-6"	5'-0"	4'-8"	7'-3"	6'-3"	5'-7"	5'-1"	4'-9"	9'-6"	8'-3"	7'-4"	6'-9"	6'-3"
180.0	4'-8"	3'-11"	5'-9"	4'-7"	4'-1"	7'-0"	6'-1"	5'-5"	4'-11"	4'-7"	7'-1"	6'-2"	5'-6"	5'-0"	4'-8"	9'-5"	8'-1"	7'-3"	6'-8"	6'-2"
185.0	4'-7"	3'-11"	5'-8"	4'-6"	4'-0"	6'-11"	6'-0"	5'-4"	4'-11"	4'-6"	7'-0"	6'-1"	5'-5"	5'-0"	4'-7"	9'-3"	8'-0"	7'-2"	6'-6"	6'-1"
190.0	4'-6"	3'-10"	5'-7"	4'-5"	4'-0"	6'-10"	5'-11"	5'-3"	4'-10"	4'-6"	6'-11"	6'-0"	5'-4"	4'-11"	4'-6"	9'-2"	7'-11"	7'-1"	6'-5"	6'-0"
195.0	4'-6"	3'-9"	5'-6"	4'-4"	3'-11"	6'-9"	5'-10"	5'-3"	4'-9"	4'-5"	6'-10"	5'-11"	5'-4"	4'-10"	4'-6"	9'-0"	7'-10"	7'-0"	6'-4"	5'-11"

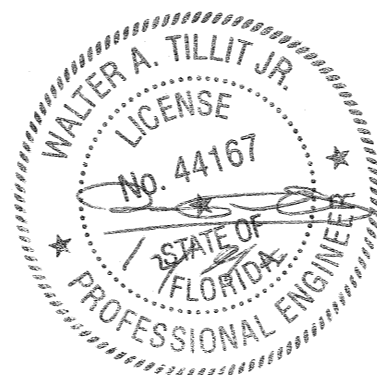

FLORIDA BUILDING CODE (Non High Velocity Hurricane Zone)

© 2011 TILTECO, INC.		ASSA/40mm & 60mm BERTHA ROLL-UP		DRAWN BY: L.G./A.G.	
 TILLIT TESTING & ENGINEERING COMPANY 6355 N.W. 36th St., Ste. 305, VIRGINIA GARDENS, FL 33166 Phone : (305)871-1530 . Fax : (305)871-1531 e-mail: tilteco@aol.com EB-0006719 WALTER A. TILLIT Jr. P.E. FLORIDA Lic. # 44167		AMERICAN SHUTTER SYSTEMS ASSOC., INC.		12/07/11 DATE	
		4268 WESTROADS DRIVE WEST PALM BEACH, FL. 33407 Phone : (877) 999-2772 . Fax : (561) 209-8380		11-209 DRAWING No	
REV. NO	DESCRIPTION	DATE	REV. No	DESCRIPTION	DATE
1	OLD 08-157	12/07/11	3		
2			4		
			SHEET 13 OF 14		

**MULLION LOADING CHART MAXIMUM A.S.D. DESIGN PRESSURE RATING (psf) AND CORRESPONDING  
MAXIMUM SPAN "L"(Ft) FOR A GIVEN TYPE OF MULLION AND MULLION SPACING (Ft).**

(USE MAXIMUM VALUES BETWEEN POSITIVE AND NEGATIVE LOAD)

MAXIMUM A.S.D. DESIGN PRESSURE RATING (p.s.f.)	TYPE 1 MULLION (N) 3" x 4" x 1/8"				TYPE 2 MULLION (O) 4" x 4" x 1/4"				TYPE 3 MULLION (P) 4" x 6" x 1/4"					
	MULLION SPACING				MULLION SPACING				MULLION SPACING					
	≤ 4'-0"	4' TO 5'	5' TO 6'	6' TO 8'	≤ 4'-0"	4' TO 5'	5' TO 6'	6' TO 8'	≤ 4'-0"	4' TO 5'	5' TO 6'	6' TO 8'	8' TO 10'	10' TO 12'
40.0 OR LESS	9'-0"	8'-4"	7'-10"	8'-2"	11'-9"	10'-11"	10'-3"	10'-9"	16'-4"	15'-2"	14'-3"	14'-10"	13'-10"	13'-0"
45.0	8'-8"	8'-0"	7'-7"	7'-10"	11'-4"	10'-6"	9'-11"	10'-4"	15'-8"	14'-7"	13'-8"	14'-4"	13'-3"	12'-6"
50.0	8'-4"	7'-9"	7'-3"	7'-7"	10'-11"	10'-2"	9'-7"	10'-0"	15'-2"	14'-1"	13'-3"	13'-10"	12'-10"	12'-1"
55.0	8'-1"	7'-6"	7'-1"	7'-4"	10'-7"	9'-10"	9'-3"	9'-8"	14'-8"	13'-7"	12'-10"	13'-4"	12'-5"	11'-8"
60.0	7'-10"	7'-3"	6'-10"	7'-2"	10'-3"	9'-7"	9'-0"	9'-5"	14'-3"	13'-3"	12'-5"	13'-0"	12'-1"	11'-4"
65.0	7'-8"	7'-1"	6'-8"	7'-0"	10'-0"	9'-4"	8'-9"	9'-2"	13'-11"	12'-11"	12'-2"	12'-8"	11'-9"	11'-1"
70.0	7'-5"	6'-11"	6'-6"	6'-10"	9'-9"	9'-1"	8'-6"	8'-11"	13'-7"	12'-7"	11'-10"	12'-4"	11'-5"	10'-9"
75.0	7'-3"	6'-9"	6'-4"	6'-8"	9'-7"	8'-10"	8'-4"	8'-8"	13'-3"	12'-3"	11'-7"	12'-1"	11'-2"	10'-6"
80.0	7'-2"	6'-7"	6'-3"	6'-6"	9'-4"	8'-8"	8'-2"	8'-6"	12'-11"	12'-0"	11'-4"	11'-10"	10'-11"	10'-4"
85.0	7'-0"	6'-6"	6'-1"	6'-4"	9'-2"	8'-6"	8'-0"	8'-4"	12'-8"	11'-9"	11'-1"	11'-7"	10'-9"	10'-1"
90.0	6'-10"	6'-4"	6'-0"	6'-3"	9'-0"	8'-4"	7'-10"	8'-2"	12'-5"	11'-7"	10'-11"	11'-4"	10'-6"	9'-11"
95.0	6'-9"	6'-3"	5'-10"	6'-2"	8'-10"	8'-2"	7'-9"	8'-1"	12'-3"	11'-4"	10'-8"	11'-2"	10'-4"	9'-9"
100.0	6'-7"	6'-2"	5'-9"	6'-0"	8'-8"	8'-1"	7'-7"	7'-11"	12'-0"	11'-2"	10'-6"	10'-11"	10'-2"	9'-7"
105.0	6'-6"	6'-1"	5'-7"	5'-11"	8'-6"	7'-11"	7'-6"	7'-9"	11'-10"	11'-0"	10'-4"	10'-9"	—	—
110.0	6'-5"	5'-11"	5'-5"	5'-10"	8'-5"	7'-10"	7'-4"	7'-8"	11'-8"	10'-10"	10'-2"	10'-7"	—	—
115.0	6'-4"	5'-10"	5'-4"	5'-8"	8'-3"	7'-8"	7'-3"	7'-7"	11'-6"	10'-8"	10'-0"	10'-5"	—	—
120.0	6'-3"	5'-9"	5'-3"	5'-7"	8'-2"	7'-7"	7'-2"	7'-5"	11'-4"	10'-6"	9'-11"	10'-4"	—	—
125.0	6'-2"	5'-7"	5'-1"	5'-5"	8'-1"	7'-6"	7'-0"	7'-4"	11'-2"	10'-4"	9'-9"	10'-2"	—	—
130.0	6'-1"	5'-6"	5'-0"	5'-4"	7'-11"	7'-5"	6'-11"	7'-3"	11'-0"	10'-3"	9'-8"	10'-0"	—	—
135.0	6'-0"	5'-5"	4'-11"	5'-3"	7'-10"	7'-3"	6'-10"	7'-2"	10'-11"	10'-1"	9'-6"	9'-11"	—	—
140.0	5'-11"	5'-3"	4'-10"	5'-2"	7'-9"	7'-2"	6'-9"	7'-1"	10'-9"	10'-0"	9'-5"	9'-10"	—	—
145.0	5'-10"	5'-2"	4'-9"	5'-1"	7'-8"	7'-1"	6'-8"	7'-0"	10'-7"	9'-10"	9'-3"	9'-8"	—	—
150.0	5'-9"	5'-1"	4'-8"	5'-0"	7'-7"	7'-0"	6'-7"	6'-11"	10'-6"	9'-9"	9'-2"	9'-7"	—	—
155.0	5'-7"	5'-0"	4'-7"	4'-11"	7'-6"	7'-0"	6'-7"	6'-10"	10'-5"	9'-8"	9'-1"	9'-6"	—	—
160.0	5'-6"	4'-11"	4'-6"	4'-10"	7'-5"	6'-11"	6'-6"	6'-9"	10'-3"	9'-7"	9'-0"	9'-4"	—	—
165.0	5'-5"	4'-10"	4'-5"	4'-9"	7'-4"	6'-10"	6'-5"	6'-8"	10'-2"	9'-5"	8'-10"	9'-3"	—	—
170.0	5'-4"	4'-10"	4'-5"	4'-8"	7'-3"	6'-9"	6'-4"	6'-8"	10'-1"	9'-4"	8'-9"	9'-2"	—	—
175.0	5'-3"	4'-9"	4'-4"	4'-7"	7'-2"	6'-8"	6'-4"	6'-7"	10'-0"	9'-3"	8'-7"	9'-1"	—	—
180.0	5'-3"	4'-8"	4'-3"	4'-6"	7'-2"	6'-7"	6'-3"	6'-6"	9'-11"	9'-2"	8'-6"	9'-0"	—	—
185.0	5'-2"	4'-7"	4'-2"	4'-6"	7'-1"	6'-7"	6'-2"	6'-5"	9'-10"	9'-1"	8'-4"	8'-11"	—	—
190.0	5'-1"	4'-6"	4'-2"	4'-5"	7'-0"	6'-6"	6'-1"	6'-5"	9'-9"	9'-0"	8'-3"	8'-9"	—	—
195.0	5'-0"	4'-6"	4'-1"	4'-4"	6'-11"	6'-5"	6'-1"	6'-4"	9'-8"	8'-11"	8'-2"	8'-8"	—	—

NOTES : REFER TO ELEVATIONS ON SHEET 1A OF 14  
 1- FOR MULLIONS INSTALLED W/O STORM BARS  
 A) MULLION SPACING SHALL BE SUCH THAT MAXIMUM SLAT SPAN SHALL NOT BE EXCEEDED  
 2- FOR MULLIONS INSTALLED W/ STORM BARS & HEADERS  
 A) MULLION SPACING SHALL BE SUCH THAT MAXIMUM HEADER SPAN SHALL NOT BE EXCEEDED  
 B) STORM BAR SPACING SHALL BE SUCH THAT MAXIMUM SLAT SPAN SHALL NOT BE EXCEEDED

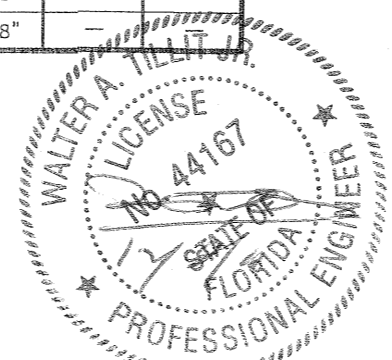

FLORIDA BUILDING CODE (Non High Velocity Hurricane Zone)

© 2011 TILTECO, INC.		ASSA/40mm & 60mm BERTHA ROLL-UP		DRAWN BY: L.G./A.G.	
 TILLIT TESTING & ENGINEERING COMPANY 6355 N.W. 36th. St., Ste. 305, VIRGINIA GARDENS, FL 33166 Phone : (305)871-1530 . Fax : (305)871-1531 e-mail: tilteco@aol.com EB-0006719 WALTER A. TILLIT Jr. P.E. FLORIDA Lic. # 44167		AMERICAN SHUTTER SYSTEMS ASSOC., INC.		12/07/11 DATE	
		4268 WESTROADS DRIVE WEST PALM BEACH, FL. 33407 Phone : (877) 999-2772 . Fax : (561) 209-8380		11-209 DRAWING No	
REV. NO	DESCRIPTION	DATE	REV. No	DESCRIPTION	DATE
1	OLD 08-157	12/07/11	3		
2			4		
					SHEET 14 OF 14